

**JOIN ZOOM MEETING:**

<https://us02web.zoom.us/j/83032452642>

+1-646-558-8656

Meeting ID: 830 3245 2642

**TOWN OF THOMPSON  
-Regular Meeting Agenda-**

THIS MEETING WILL BE HELD IN-PERSON  
LOCATED AT TOWN HALL, 4052 STATE ROUTE 42,  
MONTICELLO, NY 12701. THE MEETING WILL  
ALSO BE STREAMED LIVE ON ZOOM: TO JOIN  
PLEASE SEE TOWN WEBSITE AT:  
[WWW.TOWNOFTHOMPSON.COM](http://WWW.TOWNOFTHOMPSON.COM)

**TUESDAY, OCTOBER 03, 2023**

**7:00 PM MEETING**

CALL TO ORDER  
ROLL CALL  
PLEDGE TO THE FLAG

APPROVAL OF PREVIOUS MINUTES: September 19, 2023 Regular Town Board Meeting

PUBLIC COMMENT

CORRESPONDENCE:

- **Simonia Brown, Assistant Comptroller, Office of NYS Comptroller:** Email dated September, 2023 to Supervisor Rieber Re: Town of Thompson's fiscal stress scores and designations for FYE 2020, 2021 & 2022.

AGENDA ITEMS:

- 1) PRESENTATION OF THE 2024 FISCAL-YEAR TENTATIVE TOWN BUDGET TO TOWN BOARD, FILED 09/29/2023
- 2) ESTABLISH DATE FOR 2024 FISCAL-YEAR PRELIMINARY BUDGET PUBLIC HEARING – THURSDAY, 11/02/2023 AT 6PM
- 3) RESOLUTION TO APPLY TO THE SULLIVAN COUNTY YOUTH BUREAU FOR ADDITIONAL FUNDING TOWARDS YOUTH PROGRAMS/ACTIVITIES
- 4) HIGHWAY DEPARTMENT: REVIEW & AWARD BIDS – NEW FUEL TANK (3000 GALLON PETRO HOPPER) OPENED 09/28/2023 AT 2PM
- 5) PARKS & RECREATION DEPARTMENT ITEMS:
  - A) RESOLUTION TO DECLARE SURPLUS INVENTORY (8-ITEMS)
  - B) RESOLUTION TO DECLARE SURPLUS INVENTORY & AUTHORIZE GOING TO AUCTION (3-ITEMS)
- 6) BILLS OVER \$5,000.00
- 7) BUDGET TRANSFERS & AMENDMENTS
- 8) ORDER BILLS PAID

OLD BUSINESS  
NEW BUSINESS

REPORTS: SUPERVISOR, COUNCILMEN, & DEPARTMENT HEADS  
PUBLIC COMMENT  
ADJOURN

PLEASE TAKE NOTICE, that this Town Board meeting will be held in person and via videoconferencing, as permitted by the NYS Open Meetings Law. The zoom invite is merely a courtesy and convenience to the public. If there is a disruption in the ability of the zoom meeting to commence or even continue once a meeting has been commenced, the official meeting of the Town Board shall continue in person without interruption.

WP

**Minutes of a Regular Meeting** of the Town Board of the Town of Thompson held at the Town Hall, 4052 State Route 42, Monticello, New York and held remotely via Zoom on **September 19, 2023.**

**ROLL CALL:**

**Present:** Supervisor William J. Rieber, Jr., Presiding  
Councilman John A. Pavese  
Councilman Ryan T. Schock  
Councilman Scott S. Mace

**DRAFT**

**Absent:** Councilwoman Melinda S. Meddaugh

**Also Present:** Marilee J. Calhoun, Town Clerk  
Michael B. Mednick, Town Attorney  
Melissa DeMarmels, Town Comptroller  
James L. Carnell, Jr., Director of Building, Planning & Zoning  
Karen Schaefer, Supervisor's Confidential Secretary

**Present Via Zoom:** Kelly Murrin, Deputy Town Clerk  
Jill M. Weyer, Director of Community Development  
Michael G. Messenger, Water & Sewer Superintendent

**REGULAR MEETING – CALL TO ORDER**

Supervisor Rieber opened the meeting at 7:00 PM with the Pledge to the Flag. This meeting was held in person and remotely via Videoconferencing streamed live on the Zoom app, which is accessible to the public. The meeting is also being recorded for full transcription purposes should it be required.

Supervisor Rieber called the Tentative Special District Assessment Hearing to order at 7:00 PM for the purpose of conducting the required annual hearing.

**PUBLIC HEARING: TENTATIVE SPECIAL DISTRICT ASSESSMENT HEARING**

Supervisor Rieber opened the Public Hearing at 7:00 PM.  
Town Clerk Marilee J. Calhoun read the legal public notice and stated that she had an original Affidavit of Publication. Notice of said hearing was duly published in the Sullivan County Democrat on September 08, 2023 with the same being posted on the Town Hall Bulletin Board and Town Website on August 21, 2023.

**LEGAL NOTICE  
TOWN OF THOMPSON  
SPECIAL DISTRICT ASSESSMENT HEARING**

PLEASE TAKE NOTICE that Town Board has filed with the Town Clerk the Special District Assessment Rolls for the Adelaar Sewer District, Harris Consolidated Sewer District, Kiamesha Consolidated Sewer District, Melody Lake Sewer District, Rock Hill/Emerald Green Consolidated Sewer District, Sackett Lake Sewer District, Adelaar Water District, Cold Spring Water District, Dillon Water District, Kiamesha Route 42 Water District, Lucky Lake Water District and Melody Lake Water District for the year 2024. The Special District Assessment Rolls for all Sewer and Water Districts within the Town of Thompson are available for inspection by the Public during the normal work hours of 8:30 AM to 4:30 PM, Monday through Friday. The Town Board has determined that it will meet at the Town Hall, 4052 State Route 42, Monticello, New York at 7:00 PM on September 19, 2023 to hear and consider objections that may be made to the rolls. Said Meeting will also be held remotely by video-conference, the public may participate via video-conference at <https://us02web.zoom.us/j/83032452642>.

DATED: AUGUST 15, 2023

BY ORDER OF THE TOWN BOARD  
**MARILEE J. CALHOUN, TOWN CLERK**

Supervisor Rieber explained that the purpose of this hearing is to discuss the point system for the Special Sewer and Water Districts in the Town and how they are assessed for each user. The point rate system/schedule was explained. This hearing allows the public the opportunity to challenge any errors on the assessment of points only, not the rates. Supervisor Rieber explained the reason why this hearing is required to be held. All property owners/users in any of the Special Water and Sewer Districts were sent notification of this hearing. It is required that actual written notice of this hearing be provided to all users. The rates will be determined according to the Town Budget, which will be adopted in November.

Supervisor Rieber asked if the Board had any comments. The Board had no comments.

Supervisor Rieber asked if anyone from the public would like to be heard on this matter. There were no public comments made.

After an opportunity for all persons to be heard Supervisor Rieber entertained a motion that the hearing be closed.

A motion to close the Public Hearing at 7:02 PM was made by Councilman Schock and seconded by Councilman Pavese.

(Supervisor Rieber Recused himself from the next agenda item, because his office represents the seller of the property. He left the room and Councilman John Pavese presided over this section of the meeting.)

**2) PUBLIC HEARING: PROPOSED LOCAL LAW NO. 04 OF 2023 – AMEND CHAPTER 250, PART 6 OF THE EMERALD CORPORATE PLANNED BUSINESS DISTRICT REGULATIONS, SECTION 149B TO ADD HOTEL/MOTEL AS A PERMITTED USE**

Councilman Pavese opened the Public Hearing at 7:03 PM. Town Clerk, Marilee J. Calhoun read the legal public notice and stated that she had an original affidavit of publication. Notice of said hearing was duly published in the Sullivan County Democrat on September 08, 2023 with same being posted at the Town Hall and Town Website on August 21, 2023.

**TOWN OF THOMPSON  
NOTICE OF PUBLIC HEARING  
ON PROPOSED LOCAL LAW**

**NOTICE IS HEREBY GIVEN** that there has been duly introduced at a meeting of the Town Board of the Town of Thompson, New York, held on August 15, 2023, a proposed Local Law No. 04 of 2023, entitled “A Local Law amending Chapter 250 entitled Zoning and Planned Unit Development, Article XIX, Sections 250-149 A & B (Permitted Uses) to add a Permitted Use”.

The proposed Local Law will add Hotel/Motel as a permitted use under §§250-149 A & B.

**NOTICE IS FURTHER GIVEN** that the Town Board of the Town of Thompson will conduct a Public Hearing on the aforesaid proposed Local Law at the Town Hall, 4052 Route 42, Monticello, New York, on September 19, 2023 at 7:00 P.M., or as soon thereafter as said Public Hearing shall be convened, at which time all persons interested will be heard.

Copies of the Local Law described above are on file in the office of the Town Clerk of the Town of Thompson, where the same are available to public inspection during regular office hours.

**PLEASE TAKE FURTHER NOTICE**, that all interested persons will be given an opportunity to be heard on said proposed Local Law at the place and time aforesaid.

**NOTICE IS HEREBY GIVEN**, pursuant to the requirements of the Open Meetings Law of the State of New York, that the Town Board of the Town of Thompson will convene in public meeting at the place

**Town Board Meeting  
September 19, 2023  
Page 3 of 20**

and time aforesaid for the purpose of conducting a Public Hearing on the proposed Local Law described above and, as deemed advisable by said Board, taking action on the enactment of said Local Law.

Dated: August 15, 2023

BY ORDER OF THE TOWN BOARD

TOWN OF THOMPSON

MARILEE J. CALHOUN, TOWN CLERK

Councilman Pavese explained the purpose of Proposed Local Law No. 04 of 2023.

Councilman Pavese asked if the Board had any comments. The Board had no comments.

Councilman Pavese asked if anyone from the public would like to be heard on this matter.

Len Bernardo of Rock Hill commented on a County meeting that he attended recently regarding the Emerald Corporate Center Business District involving the future of the Water Company servicing that area.

After an opportunity for all persons to be heard Councilman Pavese entertained a motion that the public hearing be closed.

A motion to close the Public Hearing at 7:05 PM was made by Councilman Mace and seconded by Councilman Schock.

The regular meeting was reconvened at 7:06 PM.

**AGENDA ITEM:**

**1) RESOLUTION TO ENACT PROPOSED LOCAL LAW NO. 04 OF 2023 – AMEND CHAPTER 250, PART 6 OF THE EMERALD CORPORATE PLANNED BUSINESS DISTRICT REGULATIONS, SECTION 149B TO ADD HOTEL/MOTEL AS A PERMITTED USE (LOCAL LAW IS PROPOSED NO. 04, IF ADOPTED LOCAL LAW WILL BE LOCAL LAW NO. 03 OF 2023.)**

Town Clerk Calhoun reported that the GML-239 County Review was received back from the Sullivan County Division of Planning. The review included comments from the NYS DOT regarding traffic impacts. Recommendation was referred for local determination. Attorney Mednick said the next step would be to enact the local law, first by approving a Negative Declaration Resolution and second by approving the Resolution to Enact.

**The Following Resolution Was Duly Adopted: Res. No. 317 of the Year 2023.**

**Town Board Meeting  
September 19, 2023  
Page 4 of 20**

At a regular meeting of the Town Board of  
the Town of Thompson held at the Town Hall,  
4052 Route 42, Monticello, New York, on  
September 19, 2023

**RESOLUTION FOR NEGATIVE DECLARATION UNDER SEQR  
FOR PROPOSED LOCAL LAW NO. 04 OF 2023; ZONING REVISIONS**

**WHEREAS**, the Town Board of the Town of Thompson has conducted an extensive review of the present Zoning Code for the Town of Thompson, including a review of Chapter 250 of the Zoning and Planned Unit Development Code; and

**WHEREAS**, the Town Board of the Town of Thompson declared itself lead agency pursuant to Resolution dated September 19, 2023 in connection with the review of the local law to amend Chapter 250 of the Town Code; and

**WHEREAS**, a Short Form Environmental Assessment Form has been filed in connection with the proposed revisions to Chapter 250 of the Town Code; and

**WHEREAS**, a public hearing was conducted in connection with the revisions to Chapter 250 of the Town Code on September 19, 2023, wherein said public hearing was closed.

**NOW, THEREFORE, BE IT RESOLVED**, that the Town Board of the Town of Thompson determines that there are no negative environmental impacts that would be caused as a result of the enacting of Local Law 03 of 2023 entitled "A local law amending Chapter 250 entitled Zoning and Planned Unit Development, Article XIX, Sections 250-149 A & B (Permitted Uses) to add a "Permitted Use"; and

**FURTHER BE IT RESOLVED**, it is determined that the Town Board of the Town of Thompson makes a negative declaration with regard to any environmental impacts caused as a result of the enacting of Local Law No. 03 of 2023.

Moved by: Councilman Ryan T. Schock  
Seconded by: Councilman Scott S. Mace  
Adopted the 19<sup>th</sup> day of September, 2023.

The members of the Town Board voted as follows:

|                                   |         |                |
|-----------------------------------|---------|----------------|
| Supervisor WILLIAM J. RIEBER, JR. | Yes [ ] | No [ ] Recused |
| Councilman SCOTT S. MACE          | Yes [X] | No [ ]         |
| Councilman JOHN A. PAVESE         | Yes [X] | No [ ]         |

**Town Board Meeting  
September 19, 2023  
Page 5 of 20**

|                                  |         |               |
|----------------------------------|---------|---------------|
| Councilwoman MELINDA S. MEDDAUGH | Yes [ ] | No [ ] Absent |
| Councilman RYAN T. SCHOCK        | Yes [X] | No [ ]        |

**The Following Resolution Was Duly Adopted: Res. No. 318 of the Year 2023.**

At a regular meeting of the Town Board of the Town of Thompson held at the Town Hall, 4052 Route 42, Monticello, New York on September 19, 2023

**RESOLUTION TO ENACT LOCAL LAW NO. 03 of 2023**

**WHEREAS**, proposed Local Law No. 04 of the year 2023 entitled, "A Local Law amending Chapter 250 entitled Zoning and Planned Unit Development, Article XIX, Sections 250-149 A & B (Permitted Uses) to add a "Permitted Use" was introduced to the Town Board at a meeting held August 15, 2023, at the Town Hall, Monticello, New York, to consider said proposed Local Law and Notice of Public Hearing having been duly published and posted as required by law, and said Public Hearing having been held and all persons appearing at said Public Hearing deeming to be heard having been heard, and

**WHEREAS**, said Local Law was duly adopted after a Public Hearing.

**NOW, THEREFORE, BE IT RESOLVED**, that the Town Board of the Town of Thompson, New York, does hereby enact and adopt Local Law No. 03 for the year 2023, Town of Thompson, State of New York, which Local Law is annexed hereto and made a part hereof.

Moved by: Councilman Scott S. Mace

Seconded by: Councilman Ryan T. Schock

Adopted on Motion September 19, 2023

|                                   |         |                |
|-----------------------------------|---------|----------------|
| Supervisor WILLIAM J. RIEBER, JR. | Yes [ ] | No [ ] Recused |
| Councilman SCOTT S. MACE          | Yes [X] | No [ ]         |
| Councilman JOHN A. PAVESE         | Yes [X] | No [ ]         |
| Councilwoman MELINDA S. MEDDAUGH  | Yes [ ] | No [ ] Absent  |
| Councilman RYAN T. SCHOCK         | Yes [X] | No [ ]         |

Local Law No. 03 of 2023

A local law amending Chapter 250 entitled Zoning and Planned Unit Development, Article XIX, Sections 250-149 A & B (Permitted Uses) to add a "Permitted Use".

Be it enacted by the Town Board of the Town of Thompson

1. §250-149 A. is amended to add the following:

(10) Hotel/Motel, as defined in §250-2B of this Code.

2. §250-149 B is amended to add the following:

(4) Hotel/Motel, as defined in §250-2B of this Code.

3. Except as herein specifically amended, the remainder of Chapter 250 of such Code shall remain in full force and effect.

4. If any section, part or provision of this local law or the application thereof to any person, property or circumstance is adjudged invalid by any Court of competent jurisdiction, such judgment shall be confined in its operation to the section, part or application directly and expressly adjudged invalid and shall not affect or impair the validity of the remainder of this local law or the application thereof.

5. Except as herein otherwise provided penalties for the violation of this local law, any person committing an offense against any provision of the Chapter of the Code of the Town of Thompson shall, upon conviction thereof, be punishable as provided in Chapter 1, General Provisions, Article II, of such Code.

6. This local law shall take effect immediately upon filing with the Secretary of State.

Supervisor Rieber returned to the meeting after action was taken.

**APPROVAL OF MINUTES:**

On a motion made by Councilman Pavese and seconded by Councilman Schock the minutes of the August 15<sup>th</sup>, 2023 Regular Town Board Meeting were approved as presented.

Vote: Ayes 3            Rieber, Pavese and Schock  
      Nays 0  
      Absent 1        Meddaugh  
      Abstained 1    Mace (He was not present for the meeting.)

**PUBLIC COMMENT:**

Len Bernardo of Rock Hill commented on the sewer line improvements in the Emerald Green area, which started being marked.



**CORRESPONDENCE:**

Supervisor Rieber reported on correspondence that was sent or received as follows:

- **Maxine Sheehan, Personnel Assistant, SC Office of Personnel & Civil Service Administration:** Letter dated 09/01/2023 to Karen Schaefer Re: Payroll Certification through 12/31/2023.
- **NYS Dept. of Taxation & Finance:** Check #09498945 dated 09/13/23, payable to Town of Thompson in amount of \$429,403.62 for NYS DOT CHIPS 2023 Program Funding in the amount of \$381,775.62 & AIM State Aid Revenue in the amount of \$47,628.00.

**AGENDA ITEMS:**

**2) JK EXPEDITING SERVICES CORP.: CONSOLIDATED KIAMESHA SEWER DISTRICT EXTENSION NO. 3 FOR PROPERTIES LOCATED ALONG FRASER ROAD & GIBBER ROAD, KIAMESHA LAKE, SBL #'S 9.-1-8.2, 6.-1-11.1, 11.3, 11.4, 11.5 & 11.6 (EXTENSION IS TO INCLUDE PROPOSED FRASER RESORT PROJECT & PROPOSED GIBBER HOLDINGS PROJECT)**

**A) NEGATIVE DECLARATION RESOLUTION UNDER SEQRA FOR PROPOSED EXTENSION**

**The Following Resolution Was Duly Adopted: Res. No. 319 of the Year 2023.**

Resolved, that the Town Board of the Town of Thompson hereby approves a motion for a Negative Declaration as follows:

\*\*\*\*\*X

In the Matter of Extension No. 03 of the CONSOLIDATED  
KIAMESHA SEWER DISTRICT of the  
Town of Thompson, Sullivan County, New York.

**NEGATIVE DECLARATION  
UNDER SEQR**

\*\*\*\*\*X

1. The Town Board of the Town of Thompson, by Resolution duly adopted at a regular meeting thereof; held on the 19<sup>th</sup> day of September, 2023, did determine that Extension No. 03 of the Consolidated Kiamesha Sewer District in the Town of Thompson, will not have a significant effect on the environment.

2. Lead agency for such project is the Town Board of the Town of Thompson, whose address is 4052 Route 42, Monticello, New York 12701, the designation of which was accomplished by Resolution duly adopted at a regular meeting of the Town Board held on the 19<sup>th</sup> day of September, 2023.

3. The person to contact for further information is Supervisor William J. Rieber, Jr., whose address is 4052 Route 42, Monticello, New York 12701, telephone number 845-794-2500.

4. The proposed extension of the Consolidated Kiamesha Sewer District enables Frazier Lakeview Realty LLC, Rose Feldman, Elizabeth Berman, Harold Gibber and Marilyn Gibber (T/O Thompson Tax Map Parcel #'s 9-1-8.2, 6-1-11.1, 6-1-11.3, 6-1-11.4, 6-1-11.5 and 6-1-11.6) to become part of the said district and to use the facilities of the Consolidated Kiamesha Sewer Treatment Plant for the disposal of its sewage, the cost thereof being borne solely by the said property owners.

5. The basis for the negative declaration is as follows: that the administration and operation and maintenance of the sewer facilities and the use thereof by Frazier Lakeview Realty LLC, Rose Feldman, Elizabeth Berman, Harold Gibber and Marilyn Gibber (T/O Thompson Tax Map Parcel #'s 9-1-8.2, 6-1-11.1, 6-1-11.3, 6-1-11.4, 6-1-11.5 and 6-1-11.6) will not violate any of the criteria for determining environmental significance as set forth in Part 617 of the Regulations.

Dated: Monticello, New York  
September 21, 2023

TOWN OF THOMPSON  
Town Hall  
4052 Route 42  
Monticello, New York 12701

Moved by: Councilman Mace                      Seconded by: Councilman Schock  
Vote: Ayes 4                      Rieber, Schock, Pavese and Mace  
      Nays 0  
      Absent 1                      Meddaugh

**B) RESOLUTION MAKING CERTAIN DETERMINATIONS IN RELATION TO PROPOSED EXTENSION**

**The Following Resolution Was Duly Adopted: Res. No. 320 of the Year 2023.**

RESOLUTION DATED SEPTEMBER 19, 2023.

A RESOLUTION MAKING CERTAIN DETERMINATIONS IN RELATION TO PROPOSED EXTENSION NO. 03 OF THE CONSOLIDATED KIAMEHSA SEWER DISTRICT, IN THE TOWN OF THOMPSON, SULLIVAN COUNTY, NEW YORK.

WHEREAS, the Town Board of the Town of Thompson, Sullivan County, New York, has heretofore duly caused a general Map, Plan and Report to be prepared and filed in the office of the Town Clerk of said Town in relation to the proposed Extension No. 03 of the Consolidated Kiamesha Sewer District in said Town; and

WHEREAS, an Order was duly adopted by said Town Board on September 6, 2022, reciting a description of the boundaries of said proposed district, the improvements proposed, the maximum amount proposed to be expended for said improvements, the proposed method of financing to be employed, the fact that said map, plan and report were on file in the Town Clerk's Office for public inspection and specifying the 5th day of July, 2023, at 7:00 o'clock P.M., Prevailing Time, at the Town Hall, 4052 Route 42, Monticello, New York, in said Town as the time when and the place where said Town Board would meet for the purpose of holding a Public Hearing to hear all persons interested in the subject thereof concerning the same; and

WHEREAS, such Order was duly published and posted in the manner and within the time prescribed by Section 209-d of the Town Law, and proof of said publication and posting has been duly presented to said Town Board; and

WHEREAS, said Public Hearing was duly held at the time and place set forth in said Order, as aforesaid, at which all persons desiring to be heard were duly heard; and

WHEREAS, said Town Board has duly considered said Map, Plan and Report and the evidence given at said Public Hearing; NOW, THEREFORE, BE IT

RESOLVED, by the Town Board of the Town of Thompson, Sullivan County, New York, as follows:

**Section 1.** Upon the evidence given at the aforesaid Public Hearing, it is hereby found and determined as follows:

- a) The notice of the aforesaid Public Hearing was published and posted as required by law and is otherwise sufficient;
- b) All the property and property owners within said proposed district are benefitted thereby;
- c) All the property and property owners benefitted are included within the limits of said proposed district;
- d) The establishment of said proposed district is in the public interest;
- e) That the average annual cost for a typical single-family residence would be *Six Hundred Forty-One and .50/100 (\$641.50) Dollars*; and
- f) That the requirements of the State Environmental Quality Review Act have been complied with.

**Section 2.** This Resolution shall take effect immediately.

Moved by: Councilman Ryan S. Schock Seconded by: Councilman Scott S. Mace

The question of the adoption of the foregoing Resolution was duly put to a vote on roll call, which resulted as follows:

|                        |        |        |
|------------------------|--------|--------|
| William J. Rieber, Jr. | VOTING | Aye    |
| Scott S. Mace          | VOTING | Aye    |
| John A. Pavese         | VOTING | Aye    |
| Melinda S. Meddaugh    | VOTING | Absent |
| Ryan T. Schock         | VOTING | Aye    |

The resolution was thereupon declared duly adopted.

\* \* \* \* \*

**C) RESOLUTION PRELIMINARILY APPROVING PROPOSED EXTENSION  
SUBJECT TO PERMISSIVE REFERENDUM**

**The Following Resolution Was Duly Adopted: Res. No. 321 of the Year 2023.**

RESOLUTION DATED SEPTEMBER 19, 2023

A RESOLUTION APPROVING EXTENSION NO. 03 OF THE CONSOLIDATED KIAMEHSA SEWER DISTRICT IN THE TOWN OF THOMPSON, SULLIVAN COUNTY, NEW YORK, AND FURTHER APPROVING THE CONSTRUCTION OF THE IMPROVEMENTS PROPOSED THEREFOR.

WHEREAS, the Town Board of the Town of Thompson, Sullivan County, New York, has heretofore duly caused a general Map, Plan and Report to be prepared and filed with the Town Board of said Town in relation to Extension No. 03 of the Consolidated Kiamesha Sewer District in said Town; and

WHEREAS, an Order was duly adopted by said Town Board on September 6, 2022, reciting a description of the boundaries of the said proposed district, the improvements proposed, the maximum amount proposed to be expended for said improvements, the proposed method of financing to be employed, the fact that said Map, Plan and Report were on file in the Town Clerk's Office for public inspection, and specifying July 5, 2023 at 7:00 o'clock P.M., Prevailing Time, at the Town Hall, 4052 Route 42, Monticello, New York, in said Town, as the time when and the place where said Town Board would meet for the purpose of holding a Public Hearing to hear all persons interested in the subject thereof concerning the same; and

WHEREAS, such Order was duly published and posted in the manner and within the time prescribed by Section 209-d of the Town Law and proof of said publication and posting has been duly presented to said Town Board; and

WHEREAS, said Public Hearing was duly held at the time and place set forth in said Order as aforesaid, at which all persons desiring to be heard were duly heard; and

WHEREAS, following said Public Hearing and based upon the evidence given thereat, said Town Board duly adopted a Resolution determining in the affirmative all of the questions set forth in subdivision 1 of Section 209-e of the Town Law; and

WHEREAS, it is now desired to adopt a further Resolution pursuant to subdivision 2(b) of Section 209-e of the Town Law approving the establishment of said district and the construction of the improvements proposed therefor; NOW, THEREFORE, BE IT

RESOLVED, by the Town Board of the Town of Thompson, Sullivan County, New York, as follows:

**Section 1.** Extension No. 03 of the Consolidated Kiamesha Sewer District in the Town of Thompson, Sullivan County, New York, to be bounded and described as hereinafter set forth, is hereby approved and authorized. The improvement proposed for said Consolidated Sewer District as extended, consisting of providing a means by which Frazier Lakeview Realty LLC, Rose Feldman, Elizabeth Berman, Harold Gibber and Marilyn Gibber (T/O Thompson Tax Map Parcel #'s 9-1-8.2, 6-1-11.1, 6-1-11.3, 6-1-11.4, 6-1-11.5 and 6-1-11.6) may obtain sewer service by becoming part of the said Consolidated Kiamesha Sewer District, is likewise approved and authorized. The entire amount to be expended for such improvement, including, but not limited to costs of construction, engineering, administrative and legal fees, shall be borne solely and entirely by the said landowners, namely Frazier Lakeview Realty LLC, Rose Feldman, Elizabeth Berman, Harold Gibber and Marilyn Gibber. Annual charges shall be on a user consumption basis or such other method as the Town Board of the Town of Thompson shall determine by Resolution.

**Section 2.** Said District shall be bounded and described as more particularly set forth in Schedule A annexed hereto and made a part hereof.

**Section 3.** After the adoption of this Resolution, the Town Clerk is hereby directed to file certified copies of this Resolution, in accordance with and where required by law.

**Section 4.** This Resolution is adopted subject to a permissive referendum.

Motion by: Councilman Scott S. Mace                      Seconded by: Councilman Ryan T. Schock

The question of the adoption of the foregoing Resolution was duly put to a vote on roll call, which resulted as follows:

|                        |        |        |
|------------------------|--------|--------|
| William J. Rieber, Jr. | VOTING | Aye    |
| Scott S. Mace          | VOTING | Aye    |
| John A. Pavese         | VOTING | Aye    |
| Melinda S. Meddaugh    | VOTING | Absent |
| Ryan T. Schock         | VOTING | Aye    |

The resolution was thereupon declared duly adopted.

### **SCHEDULE "A"**

Consolidated Kiamesha Sewer District Ext. No. 3

July 2022

Beginning at a point, being the southwest corner of TM 9-1-8.2, said corner also being on the centerline of Fraser Road; Thence

1. Northeasterly, 293 feet more or less, along the eastern boundary of TM 9-1-8.3 to a point; thence
2. Northerly, 549 feet more or less, along the easterly boundary of TM 9-1-8.3 to a point; thence
3. Northeasterly, 209 feet more or less, along the easterly boundary of TM 9-1-8.3 to a point, said point being the northeasterly corner of TM 9-1-8.3; thence
4. Westerly, 556 feet more or less, along the northerly boundary of TM 9-1-8.3, to a point, said point being the northwesterly corner of TM 9-1-8.; thence
5. Northerly, 2,283 feet more or less, along the easterly boundary of TM 9-1-1.1 to a point, said point being the Northwesterly corner of TM 9-1-8.2; thence
6. Easterly, 291 feet more or less, along the southerly boundary of TM 6-1-11.7 to a point, said point being the westerly corner of TM 6-1-11.1; thence
7. Northeasterly, 1,288 feet more or less, along the northerly boundary of TM 6-1-11.1 and TM 6-1-11.6 to a point, said point being the northwesterly corner of TM 6-1-11.1 and the center of Gibber Road; thence





Nays 0  
Absent 1 Meddaugh

**4) PARKS & RECREATION DEPARTMENT ITEMS:**

- A) **RESOLUTION TO AUTHORIZE ELEMENTARY BASKETBALL PROGRAM AT RUTHERFORD ELEMENTARY SCHOOL FROM 9AM-12PM, SATURDAYS, NOVEMBER 4<sup>TH</sup>, 11<sup>TH</sup>, 18<sup>TH</sup> & 25<sup>TH</sup> & DECEMBER 2<sup>ND</sup>, 9<sup>TH</sup>, 16<sup>TH</sup>, 23<sup>RD</sup> & 30<sup>TH</sup> WITH STEFON MCGINNIS AT A COST OF \$75.00/SESSION FOR 9-WEEKS, TOTAL COST NOT TO EXCEED \$675.00**

The Following Resolution Was Duly Adopted: Res. No. 324 of the Year 2023.

Resolved, that the Town Board of the Town of Thompson hereby approves the proposal of Stefon McGinnis for the operation of a Youth Basketball Program in the Town of Thompson upon request of the Parks and Recreation Department on Saturday's, November 4<sup>th</sup>, 11<sup>th</sup>, 18<sup>th</sup> & 25<sup>th</sup> & December 2<sup>nd</sup>, 9<sup>th</sup>, 16<sup>th</sup>, 23<sup>rd</sup> & 30<sup>th</sup> (9-weeks) at a cost of \$75.00 per session, maximum cost not to exceed \$675.00. All events to be held at the KL Rutherford Elementary School from 9am to 12pm.

Moved by: Councilman Pavese                      Seconded by: Councilman Schock

Vote: Ayes 4              Rieber, Pavese, Schock and Mace

Nays 0

Absent 1              Meddaugh

**5) DISCUSS RE-SCHEDULING TUESDAY, NOVEMBER 7<sup>TH</sup> TOWN BOARD MEETING TO NOVEMBER 2<sup>ND</sup> OR 8<sup>TH</sup> DUE TO GENERAL ELECTION DAY**

The Following Resolution Was Duly Adopted: Res. No. 325 of the Year 2023.

Resolved, that due to General Election Day, the Tuesday, November 7<sup>th</sup>, 2023 regularly scheduled Town of Thompson Town Board meeting hereby be rescheduled to Thursday, November 2<sup>nd</sup>, 2023 at 6:00 PM and the Town Clerk is hereby directed to advertise same in the official newspaper of the Town.

Moved by: Councilman Pavese                      Seconded by: Councilman Mace

Vote: Ayes 4              Rieber, Schock, Pavese and Mace

Nays 0

Absent 1              Meddaugh

**6) BILLS OVER \$5,000.00 – WATER & SEWER DEPARTMENT**

The Following Resolution Was Duly Adopted: Res. No. 326 of the Year 2023.

Resolved, that the following bills over \$5,000.00 for the Water & Sewer Department be approved for payment as follows:

**MHE Engineering**

**\$5,000.00 Total Cost**

Invoice # 16205 – Engineering Services through July 2023 for the Emerald Green Pump Station #6 EPG Study, Project # 22-715.

**Delaware Engineering**

**\$25,782.20 Total Cost**

**Town Board Meeting**

**September 19, 2023**

**Page 16 of 20**

Invoice # 20-2090-12 – Engineering Services through August 2023 on the Kiamesha Lake WWTP Upgrade Project.

Moved by: Councilman Mace                      Seconded by: Councilman Pavese  
 Vote: Ayes 4                      Rieber, Pavese, Schock and Mace  
       Nays 0  
       Absent 1                      Meddaugh

**7) BUDGET TRANSFERS & AMENDMENTS**

To:        Town of Thompson - Supervisor and Council  
 From:     Melissa DeMarmels - Comptroller  
  
 Re:        Budget Transfers & Amendments - FYE 12/31/23

            Board  
 Date:     Meeting    9/19/2023

Memo: The following Budget Transfers & Amendments are proposed for the following purposes:

- 1)            Amend A Fund budget to cover Parks gator purchase with additional interest earnings
  
- 2)            Transfer funds from loan principal to contractual in Rock Hill Lighting District.
  
- 3)            Transfer funds from retiree health insurance to active employee insurance in DB Fund

**The Following Resolution Was Duly Adopted: Res. No. 327 of the Year 2023.**

Resolved, that the following budgetary transfers/amendments hereby be approved as presented.

**Town Of Thompson**

**Budget Transfers/Amendments**

FYE 12/31/23                      Town Board Meeting Date: 9/19/2023

| <u>Account Number</u> | <u>Account Description</u> |  | <u>Revenue Increase</u> | <u>Revenue Decrease</u> | <u>Appropriation Increase</u> | <u>Appropriation Decrease</u> |
|-----------------------|----------------------------|--|-------------------------|-------------------------|-------------------------------|-------------------------------|
|                       |                            |  |                         |                         |                               |                               |

|               |   |  |           |  |           |          |
|---------------|---|--|-----------|--|-----------|----------|
| A000.7110.200 | Park - Equipment                        |  |           |  | 13,500.00 |          |
| A000.2401.000 | Interest & Earnings                     |  | 13,500.00 |  |           |          |
|               |   |  |           |  |           |          |
| SL01.5182.400 | Street Lighting Contractual - Rock Hill |  |           |  | 1,500.00  |          |
| SL01.9790.600 | State Loan - Principal                  |  |           |  |           | 1,500.00 |
|               |   |  |           |  |           |          |
| DB00.9060.800 | Hospital/Medical Insurance              |  |           |  | 2,500.00  |          |
| DB00.9060.802 | Retiree Hospital/Medical Insurance      |  |           |  |           | 2,500.00 |
|               |   |  |           |  |           |          |
|               |   |  |           |  |           |          |

Totals      13,500.00      -      17,500.00      4,000.00

Net Effect To Budget

Moved by: Councilman Schock                      Seconded by: Councilman Pavese  
Vote: Ayes 4              Rieber, Pavese, Schock and Mace  
      Nays 0  
      Absent 1              Meddaugh

**8) ORDER BILLS PAID**

**The Following Resolution Was Duly Adopted: Res. No. 328 of the Year 2023.**

Resolved, that all regular bills for the course of the month, which have been properly audited be approved for payment. A complete list of the regular bills as identified can be found appended to these minutes as per attached.<sup>1</sup>

Moved by: Councilman Mace                      Seconded by: Councilman Schock  
Vote: Ayes 4              Rieber, Pavese, Schock and Mace  
      Nays 0  
      Absent 1              Meddaugh

**OLD BUSINESS**

There was no old business reported on.

**NEW BUSINESS**

**1) ESTABLISH DATES FOR BUDGET WORK-SESSIONS**

**The Following Resolution Was Duly Adopted: Res. No. 329 of the Year 2023.**

<sup>1</sup> ATTACHMENT: ORDER BILLS PAID

Resolved, that the Town Board of the Town of Thompson hereby schedules (2) Budget Work-Sessions for Thursday, October 12<sup>th</sup>, 2023 and Tuesday, October 17<sup>th</sup>, 2023 at 5:00 PM to be held at the Town Hall, 4052 State Route 42, Monticello, New York for the purpose of reviewing and discussing the 2024 Fiscal-Year Tentative Budget. Now, Therefore, Be It Resolved, that the work-sessions will be held in-person. Further Be It Resolved that the Town Clerk is hereby directed to publish notice of said work-sessions in the official newspaper of the Town.

Moved by: Councilman Schock                      Seconded by: Councilman Pavese

Vote: Ayes 4                      Rieber, Pavese, Schock and Mace

Nays 0

Absent 1                      Meddaugh

### **REPORTS: SUPERVISOR, COUNCILMEN, & DEPARTMENT HEADS**

#### **Supervisor William J. Rieber, Jr.**

- No report provided.

#### **Councilman John A. Pavese**

- Monticello Fire Departments Annual Firemen's Sportsman's Raffle/Dinner to be held on Saturday, 09/23/2023 at Firemen's Camp from 2PM-8PM.

### **PUBLIC COMMENT**

There was no public comment given.

### **ANNOUNCEMENTS, REMINDERS & FOR YOUR INFORMATION**

- 10/03/23 at 7PM: Regular Town Board Meeting.
- 09/28/23 at 2PM: Bid Opening – New Fuel Tank (3000-Gal Petro Hopper).

### **EXECUTIVE SESSION**

On a motion made by Councilman Pavese and seconded by Councilman Schock the Town Board entered into Executive Session at 7:22 PM with Attorney Mednick to discuss a personnel matter.

The Zoom Livestream Videoconferencing connection was disconnected.

Executive Session was held.

On a motion made by Councilman Pavese and seconded by Councilman Schock the Town Board returned from Executive Session at 7:29 PM. There was no further action taken. Further action was taken as follows:

### **AUTHORIZE HIRING OF A 3<sup>RD</sup> PART-TIME COURT OFFICER**

**The Following Resolution Was Duly Adopted: Res. No. 330 of the Year 2023.**

Resolved that Town of Thompson Supervisor William J. Rieber, Jr. hereby be authorized to hire a 3<sup>rd</sup> Part-Time Court Officer in the Town of Thompson Justice Court

conditioned upon the approval of the two Town Justices and meeting Civil Service requirements for hiring.

Moved by: Councilman Pavese                      Seconded by: Councilman Schock

Vote: Ayes 4              Rieber, Pavese, Schock and Mace

Nays 0

Absent 1              Meddaugh

**ADJOURNMENT**

On a motion made by Councilman Schock and seconded by Councilman Pavese the meeting was adjourned at 7:30 PM. All board members voted in favor of adjourning the meeting.

The Zoom Livestream Videoconferencing connection was disconnected.

**Respectfully Submitted By:**



Marilee J. Calhoun, Town Clerk

7



Town of Thompson  
Warrant Report

Town of Thompson  
Warrant Report

I hereby certify that the vouchers listed on the attached abstracts of prepaid and claims payable have been duly audited and are presented for payment to the Town Board of the Town of Thompson at the regular meeting there of, held on the 19<sup>th</sup> day of September 2025 in the amounts respectively specified. Authorization is hereby given and direction is made to pay each of the claimants in the amount as specified upon each claim stated.

  
Melissa DeMareels, Comptroller

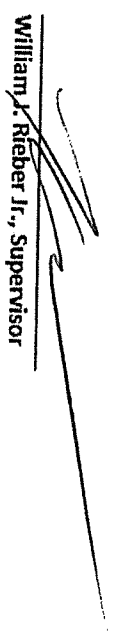
  
William J. Riaber Jr., Supervisor



Town of Thompson  
Warrant Report

| Fund                               | Fund Description    | Invoice Batch | Manual Checks | Purchase Cards     | Total              |
|------------------------------------|---------------------|---------------|---------------|--------------------|--------------------|
| T000                               | TRUST & AGENCY FUND | \$0.00        | \$0.00        | \$14,473.18        | \$14,473.18        |
| <b>Unposted Batch Grand Totals</b> |                     | <b>\$0.00</b> | <b>\$0.00</b> | <b>\$14,473.18</b> | <b>\$14,473.18</b> |

| Fund  | Fund Description                                | Invoice Batch |        | Manual Checks |        | Purchase Cards |        | Total        |        |
|-------|---|---------------|--------|---------------|--------|----------------|--------|--------------|--------|
|       |   | Paid          | Unpaid | Paid          | Unpaid | Paid           | Unpaid | Paid         | Unpaid |
| A000  | GENERAL FUND TOWN WIDE                          | \$194,571.06  | \$0.00 | \$0.00        | \$0.00 | \$0.00         | \$0.00 | \$194,571.06 | \$0.00 |
| B000  | GENERAL TOWN OUTSIDE                            | \$367,471.81  | \$0.00 | \$0.00        | \$0.00 | \$0.00         | \$0.00 | \$367,471.81 | \$0.00 |
| DA00  | HWY#3 / 4 - TOWN WIDE                           | \$89,889.22   | \$0.00 | \$0.00        | \$0.00 | \$0.00         | \$0.00 | \$89,889.22  | \$0.00 |
| DB00  | HWY#1 - TOWN OUTSIDE                            | \$91,411.97   | \$0.00 | \$0.00        | \$0.00 | \$0.00         | \$0.00 | \$91,411.97  | \$0.00 |
| H000  | CAPITAL PROJECTS                                | \$25,782.20   | \$0.00 | \$0.00        | \$0.00 | \$0.00         | \$0.00 | \$25,782.20  | \$0.00 |
| SL01  | ROCK HILL LIGHTING                              | \$415.49      | \$0.00 | \$0.00        | \$0.00 | \$0.00         | \$0.00 | \$415.49     | \$0.00 |
| SL02  | LUCKY LAKE LIGHTING                             | \$69.74       | \$0.00 | \$0.00        | \$0.00 | \$0.00         | \$0.00 | \$69.74      | \$0.00 |
| SL03  | LAKE LOUISE MARIE                               | \$215.59      | \$0.00 | \$0.00        | \$0.00 | \$0.00         | \$0.00 | \$215.59     | \$0.00 |
| SL04  | PATIO HOMES LIGHTING                            | \$157.47      | \$0.00 | \$0.00        | \$0.00 | \$0.00         | \$0.00 | \$157.47     | \$0.00 |
| SL05  | KAMESHA SHORES LIGHTING                         | \$58.14       | \$0.00 | \$0.00        | \$0.00 | \$0.00         | \$0.00 | \$58.14      | \$0.00 |
| SL06  | EMERALD GREEN LIGHTING                          | \$1,099.48    | \$0.00 | \$0.00        | \$0.00 | \$0.00         | \$0.00 | \$1,099.48   | \$0.00 |
| SL07  | TREASURE LAKE LIGHTING                          | \$14.39       | \$0.00 | \$0.00        | \$0.00 | \$0.00         | \$0.00 | \$14.39      | \$0.00 |
| SL08  | CONGERO ROAD LIGHTING                           | \$41.20       | \$0.00 | \$0.00        | \$0.00 | \$0.00         | \$0.00 | \$41.20      | \$0.00 |
| SL09  | YESHIVAKIAM LIGHTING DISTRICT                   | \$173.93      | \$0.00 | \$0.00        | \$0.00 | \$0.00         | \$0.00 | \$173.93     | \$0.00 |
| SL10  | EMERALD CORP. PARK L/D#10                       | \$110.10      | \$0.00 | \$0.00        | \$0.00 | \$0.00         | \$0.00 | \$110.10     | \$0.00 |
| SL11  | ADELAAR Lighting                                | \$537.54      | \$0.00 | \$0.00        | \$0.00 | \$0.00         | \$0.00 | \$537.54     | \$0.00 |
| SL12  | Route 42 N Lighting                             | \$7.51        | \$0.00 | \$0.00        | \$0.00 | \$0.00         | \$0.00 | \$7.51       | \$0.00 |
| SSAR  | Adelaar Sewer District                          | \$11,010.31   | \$0.00 | \$0.00        | \$0.00 | \$0.00         | \$0.00 | \$11,010.31  | \$0.00 |
| SSHHC | Harris Consolidated Sewer District              | \$11,153.01   | \$0.00 | \$0.00        | \$0.00 | \$0.00         | \$0.00 | \$11,153.01  | \$0.00 |
| SSKC  | Klamesha Consolidated Sewer District            | \$51,883.91   | \$0.00 | \$0.00        | \$0.00 | \$0.00         | \$0.00 | \$51,883.91  | \$0.00 |
| SSM0  | MELODY LAKE SEWER DISTR.                        | \$2,588.32    | \$0.00 | \$0.00        | \$0.00 | \$0.00         | \$0.00 | \$2,588.32   | \$0.00 |
| SSRC  | Rock Hill Emerald Green Consolidated Sewer Dist | \$34,527.09   | \$0.00 | \$0.00        | \$0.00 | \$0.00         | \$0.00 | \$34,527.09  | \$0.00 |
| SSSO  | SACKETT LAKE SEWER DISTR                        | \$14,110.25   | \$0.00 | \$0.00        | \$0.00 | \$0.00         | \$0.00 | \$14,110.25  | \$0.00 |
| SWA0  | ADELAAR RESORT WATER DISTRICT                   | \$1,607.05    | \$0.00 | \$0.00        | \$0.00 | \$0.00         | \$0.00 | \$1,607.05   | \$0.00 |
| SWCO  | COLD SPRING WATER                               | \$501.54      | \$0.00 | \$0.00        | \$0.00 | \$0.00         | \$0.00 | \$501.54     | \$0.00 |
| SWDO  | DILLON WATER DISTRICT                           | \$50.87       | \$0.00 | \$0.00        | \$0.00 | \$0.00         | \$0.00 | \$50.87      | \$0.00 |
| SWKO  | KIAMESHA RT42 WATER                             | \$130.18      | \$0.00 | \$0.00        | \$0.00 | \$0.00         | \$0.00 | \$130.18     | \$0.00 |
| SWLD  | LUCKY LAKE WATER DISTR                          | \$3,590.90    | \$0.00 | \$0.00        | \$0.00 | \$0.00         | \$0.00 | \$3,590.90   | \$0.00 |
| SWNO  | MELODY LAKE WATER                               | \$0.00        | \$0.00 | \$0.00        | \$0.00 | \$0.00         | \$0.00 | \$0.00       | \$0.00 |



Town of Thompson  
Warrant Report

| Fund                | Fund Description                                | Invoice Batch | Manual Checks | Purchase Cards | Total          |
|---------------------|---|---------------|---------------|----------------|----------------|
|                     |   | Paid          | Unpaid        | Paid           | Unpaid         |
| T000                | TRUST & AGENCY FUND                             | \$5,514.68    | \$0.00        | \$0.00         | \$0.00         |
| Posted Batch        | Grand Totals                                    | \$910,117.97  | \$0.00        | \$321,043.26   | \$1,231,161.23 |
| Report Grand Totals |   |               |               |                | \$0.00         |
| A000                | GENERAL FUND TOWN WIDE                          | \$194,571.06  | \$0.00        | \$0.00         | \$194,571.06   |
| B000                | GENERAL TOWN OUTSIDE                            | \$367,471.81  | \$0.00        | \$0.00         | \$367,471.81   |
| DA00                | HWY#3 / 4 - TOWN WIDE                           | \$89,889.22   | \$0.00        | \$0.00         | \$89,889.22    |
| DB00                | HWY#1 - TOWN OUTSIDE                            | \$91,411.97   | \$0.00        | \$0.00         | \$91,825.31    |
| H000                | CAPITAL PROJECTS                                | \$25,782.20   | \$0.00        | \$0.00         | \$25,782.20    |
| SLO1                | ROCK HILL LIGHTING                              | \$415.49      | \$0.00        | \$0.00         | \$415.49       |
| SLO2                | LUCKY LAKE LIGHTING                             | \$69.74       | \$0.00        | \$0.00         | \$69.74        |
| SLO3                | LAKE LOUISE MARIE                               | \$215.59      | \$0.00        | \$0.00         | \$215.59       |
| SLO4                | PATIO HOMES LIGHTING                            | \$157.47      | \$0.00        | \$0.00         | \$157.47       |
| SLO5                | KIAMESHA SHORES LIGHTING                        | \$58.14       | \$0.00        | \$0.00         | \$58.14        |
| SLO6                | EMERALD GREEN LIGHTING                          | \$1,099.48    | \$0.00        | \$0.00         | \$1,099.48     |
| SLO7                | TREASURE LAKE LIGHTING                          | \$14.39       | \$0.00        | \$0.00         | \$14.39        |
| SLO8                | CONGERO ROAD LIGHTING                           | \$41.20       | \$0.00        | \$0.00         | \$41.20        |
| SLO9                | YESHIVAKIAM LIGHTING DISTRICT                   | \$173.93      | \$0.00        | \$0.00         | \$173.93       |
| SLO10               | EMERALD CORP. PARK L/D#10                       | \$110.10      | \$0.00        | \$0.00         | \$110.10       |
| SL11                | ADELAAR Lighting                                | \$537.54      | \$0.00        | \$0.00         | \$537.54       |
| SL12                | Route 42 N Lighting                             | \$7.51        | \$0.00        | \$0.00         | \$7.51         |
| SSAR                | Adelaar Sewer District                          | \$11,010.31   | \$0.00        | \$0.00         | \$11,010.31    |
| SSHHC               | Harris Consolidated Sewer District              | \$11,153.01   | \$0.00        | \$0.00         | \$11,153.01    |
| SSKC                | Kiamasha Consolidated Sewer District            | \$51,883.91   | \$0.00        | \$0.00         | \$51,883.91    |
| SSMO                | MELODY LAKE SEWER DISTR.                        | \$2,588.32    | \$0.00        | \$0.00         | \$2,588.32     |
| SSRC                | Rock Hill Emerald Green Consolidated Sewer Dist | \$34,527.09   | \$0.00        | \$0.00         | \$34,527.09    |
| SSSO                | SACKETT LAKE SEWER DISTR                        | \$14,110.25   | \$0.00        | \$0.00         | \$14,110.25    |
| SWA0                | ADELAAR RESORT WATER DISTRICT                   | \$1,607.05    | \$0.00        | \$0.00         | \$1,607.05     |
| SWC0                | COLD SPRING WATER                               | \$1,423.02    | \$0.00        | \$0.00         | \$1,423.02     |
| SWD0                | DILLON WATER DISTRICT                           | \$501.54      | \$0.00        | \$0.00         | \$501.54       |
| SWK0                | KIAMESHA RT42 WATER                             | \$50.87       | \$0.00        | \$0.00         | \$50.87        |
| SWLD                | LUCKY LAKE WATER DISTR                          | \$130.18      | \$0.00        | \$0.00         | \$130.18       |
| SWMO                | MELODY LAKE WATER                               | \$3,590.90    | \$0.00        | \$0.00         | \$3,590.90     |
| T000                | TRUST & AGENCY FUND                             | \$5,514.68    | \$0.00        | \$0.00         | \$5,514.68     |
| Grand Totals        |   | \$910,117.97  | \$0.00        | \$321,043.26   | \$1,231,161.23 |



Dear Town Supervisor Rieber:

The Office of the State Comptroller uses the Fiscal Stress Monitoring System to examine the annual financial information reported by your Town. This analysis provides an objective assessment of the fiscal challenges facing individual local governments and school districts, identifying situations where corrective action may be needed. These 2022 scores are based on fiscal year-end results.

As of August 31, 2023, our review of the 2022 Annual Financial Report (AFR) for your Town has been completed. Detailed information about your Town's fiscal stress condition is available on our [website](#) by using the user name and password above.

Your Town's fiscal stress scores and designations are summarized below:

| FYE  | Fiscal Stress |                | Score | Environmental Stress             |  |
|------|---------------|----------------|-------|----------------------------------|--|
|      | Score         | Designation    |       | Designation                      |  |
| 2020 | 6.7           | No Designation | 33.3  | Susceptible Environmental Stress |  |
| 2021 | 3.3           | No Designation | 23.3  | No Designation                   |  |
| 2022 | 3.3           | No Designation | 23.3  | No Designation                   |  |

We encourage you to closely monitor your financial condition in the current and upcoming budget cycles. Our [self-assessment tool](#) allows you to calculate fiscal stress scores based on current and future financial assumptions, and can be a powerful tool.

Fiscal stress scores for all calendar fiscal year-end local governments will be released to the public in the near future and you may receive questions about your score/designation as well as any notable changes and trends. We recently conducted a webinar to help local government officials understand how to interpret their scores and to prepare for public inquiries and media reaction. If you were unable to participate, you may view it [here](#).

More information about the System is available on our [website](#).

Please contact the Data Management Unit at 866-321-8503, option 4 with any questions.

Sincerely,

**Simonia Brown**

Assistant Comptroller

cc: CEO

Office of the New York State Comptroller  
110 State Street - Albany, NY 12236



Notice: This communication, including any attachments, is intended solely for the use of the individual or entity to which it is addressed. This communication may contain information that is protected from disclosure under State and/or Federal law. Please notify the sender immediately if you have received this communication in error and delete this email from your system. If you are not the intended recipient, you are requested not to disclose, copy, distribute or take any action in reliance on the contents of this information.

AI  
#3

## **Marilee Calhoun (Town of Thompson)**

---

**From:** Jill Weyer (Town of Thompson) <jweyer@townofthompson.com>  
**Sent:** Thursday, September 28, 2023 4:03 PM  
**To:** 'marilee (clerk-town of thompson)'  
**Subject:** FW: Youth Bureau Funding

**From:** Jill Weyer (Town of Thompson) <jweyer@townofthompson.com>  
**Sent:** Thursday, September 28, 2023 2:54 PM  
**To:** 'Supervisor Rieber ' <supervisor@townofthompson.com>;  
<clerk@villageofmonticello.com>  
**Cc:** 'jferriero@townofthompson.com' <jferriero@townofthompson.com>; 'Glenn Somers'  
<gsomers@townofthompson.com>  
**Subject:** Youth Bureau Funding

I just saw on Facebook that the next round of Youth Bureau funding is due October 24, 2023. I've sent an email to clarify what else we can apply for, but it would be great to get a resolution to apply for additional funds for all 3 programs – YDP, YSEF and State Teams to continue to fund our programs. Let me know what else you need from me and I'll have more information by the meeting. Thanks!

# **Applications Now Being Accepted for Youth Bureau Funding**

Tuesday, September 26, 2023

Monticello, NY – The Sullivan County Youth Bureau is now accepting grant applications from organizations which serve children and youth within Sullivan County.

The Youth Bureau receives monies annually from the County and the New York State Office of Children and Family Services (OCFS) to fund youth development programs. This year, OCFS, has made available 3 funding sources: Youth Development Programs (YDP), State Youth Sports Education Funding (YSEF) and State Teams.

Applications and descriptions of requirements for each funding source – and information regarding which one will best meet the needs of your program – can be found at <https://Sullivanyny.us/Departments/Youthbureau>.

Eligible applicants include private nonprofit organizations, schools and municipalities. Organizations that would like to be considered for funding should submit completed applications by Tuesday, October 24, 2023. All applications need to be submitted electronically to [Kristen.Kitson2@Sullivanny.us](mailto:Kristen.Kitson2@Sullivanny.us).

New applicants MUST virtually attend a Zoom meeting on Tuesday, October 10, 2023 to review their application and the claim and funding process. This will include the opportunity to ask questions: <https://us06web.zoom.us/j/85345106071?pwd=jqlXiNs4Yq7Bh0JgNw3WtB7leGCYb>  
m. Meeting ID: 853 4510 6071

Passcode: 787637

For more information, please call the Sullivan County Youth Bureau at 845-807-0394.

*Jill M. Weyer*

Director of Community Development  
Town of Thompson  
4052 Route 42  
Monticello, NY 12701  
Phone: 845-794-2500 Ext. 304  
Fax: 845-794-8600



*The Town of Thompson is an equal opportunity provider and employer.*

#4

One New 3000 gal. Highland Tank 3000 gal Petro Hopper with factory white finish as per attached specification sheet, installed to existing gasoline pump. Bidder will remove and decommission existing Petro Hopper and comply with all NYS DEC regulations. Bidder will assist and furnish updated bulk storage permit to town.

Price for One New 3000gal Petro Hopper Installed: \$ 25,495.49

|                                 |                             |
|---------------------------------|-----------------------------|
| <u>SMP Pump &amp; Tank Inc.</u> | <u>845-796-1660</u>         |
| Company Name                    | Telephone                   |
| <u>Stephen PAULAK</u>           | <u>285 Old Rt 17</u>        |
| Contact Person(s)               | Address                     |
| <u>Owner</u>                    | <u>Monticello, NY 12701</u> |
| Title(s)                        | City, State, Zip            |
| <u>Stephen Paulak</u>           | <u>9-26-2023</u>            |
| Signature                       | Date                        |

\*\*\*\*\*Do not write below this line\*\*\*\*\*

ACCEPTED [ ] Date: \_\_\_\_\_

REJECTED [ ]

Comments:  
\_\_\_\_\_  
\_\_\_\_\_

\_\_\_\_\_  
Signature

NOTE: ALL RIGHTS RESERVED. THIS DRAWING MUST NOT BE REPRODUCED IN ANY FORM WITHOUT THE WRITTEN PERMISSION OF HIGHLAND TANK. HIGHLAND TANK SHALL BE RESPONSIBLE FOR THE DESIGN AND CONSTRUCTION OF THIS TANK. HIGHLAND TANK SHALL BE RESPONSIBLE FOR VERIFYING CORRECTNESS OF SIZE AND WEIGHT OF MATERIALS, DIMENSIONS, AND COATINGS SHOWN ON THIS DRAWING. TOUCH UP OF FINISHED PAINT IS REQUIRED BY INSTALLATION CONTRACTOR. TOUCH UP PAINT SHIPPED WITH TANK.

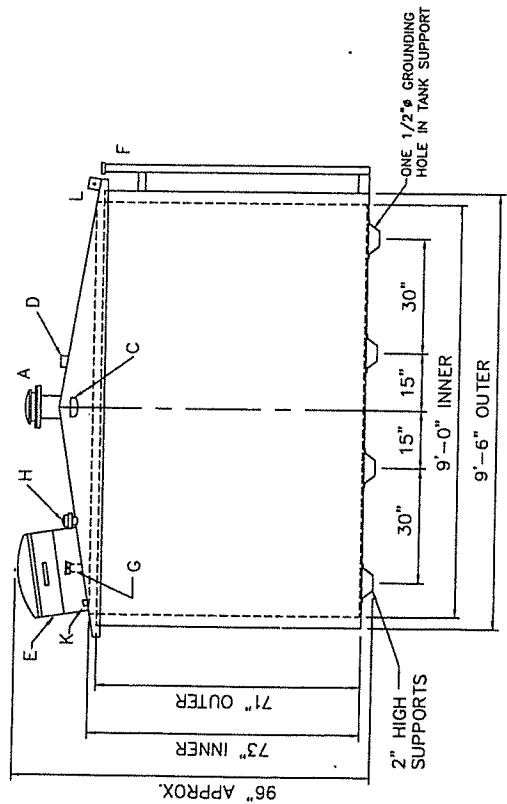
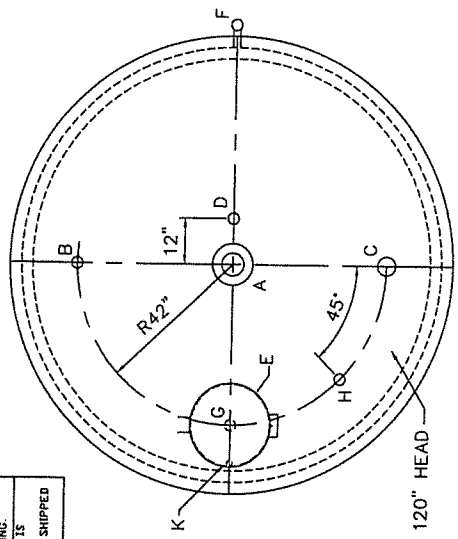

**DESIGN DATA**

CAPACITY - 3,000 GALLONS  
 NO. REQ. -  
 OPERATING PRESSURE - ATMOSPHERIC  
 SPECIFIC GRAVITY = 1.0  
 TANK MATERIAL - MILD CARBON STEEL  
 THICKNESS - TOP: 1/4" FLANGED CONE OR STD. FLANGED & DISHED  
 THICKNESS - BALANCE OF TANK - 7 GA  
 CONSTRUCTION - TANK - LAP WELD OUTSIDE ONLY (INNER TANK IS NOT ATTACHED TO OUTER TUB)  
 CONSTRUCTION - TUB - LAP WELD OUTSIDE ONLY  
 TANK TEST - TANK ONLY - 5 PSIG  
 TUB TEST - TUB ONLY - WATERTIGHT  
 FINISH - TUB - INSIDE AND OUT - SHOP PRIMER  
 FINISH - TANK - INTERIOR - NONE  
 FINISH - TANK - EXTERIOR - SAME AS TUB  
 LABEL - UL 142 - APPLY LABEL ON TOP OF TANK  
 TANK SUPPORT - 10 GA X 4" WIDE X 2" DEEP PRESSBRAKE "U" PATTERN

**LEGEND**

|   |   |
|---|---|
| A | 6" FFSO 150# FLANGE - PRIMARY EMERGENCY VENT USE ONLY   |
| B | 2" HALF COUPLING (SUCTION)  |
| C | 4" COUPLING (SPARE)   |
| D | 2" HALF COUPLING (NORMAL VENT)  |
| E | 22" CHAMBER WITH HINGED ALUMINUM LID SEE DETAIL E APPROXIMATE CHAMBER CAPACITY 7 GAL ACCESS TO FILL   |
| F | 2" MONITOR PIPE   |
| G | 4" HALF COUPLING WITH 4" X 2" DOUBLE TAPPED BUSHING W/2" CLOSE NIPPLE & 2" LOCKING FILL CAP   |
| H | 2" HALF COUPLING (GAUGE)  |
| J | -   |
| K | 1/2" FITTING W/PLUG - PLACE INSIDE CHAMBER AS CLOSE AS POSSIBLE TO EDGE - CHAMBER DRAIN   |
| L | 3" X 3" PLATE W/ 1/2" HOLE (MIN.) HOLE ON CENTER (GROUNDING LUG - ONE REQ'D ON THE LID), HTM SHOP TO DRILL ONE 1/2" HOLE IN THE TANK SUPPORT. |

SHIP LOOSE: (INSTALLATION BY OTHERS)

- (1) GAUGE
- (1) 2" x 96" LONG GALVANIZED PIPE (T.B.E.)
- (1) 2" MUSHROOM VENT
- (1) 6" EMERGENCY VENT

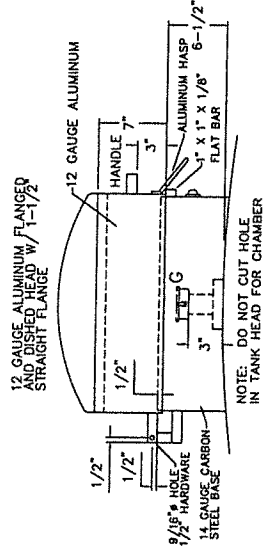
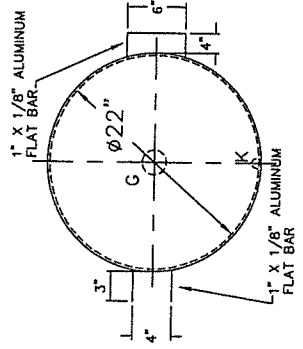

NOTE: DO NOT CUT HOLE IN TANK HEAD FOR CHAMBER

**DETAIL E**



**Highland Tank**

UNLESS NOTED, TOLERANCES ARE +/- .1"

## 3,000 GAL PETRO HOPPER

|              |        |
|--------------|--------|
| CUSTOMER:    |        |
| PROJECT:     |        |
| QUOTE NO.:   |        |
| SCALE:       | DATE:  |
| 3/8" = 1'-0" | 3000PH |

One New 3000 gal. Highland Tank 3000 gal Petro Hopper with factory white finish as per attached specification sheet, installed to existing gasoline pump. Bidder will remove and decommission existing Petro Hopper and comply with all NYS DEC regulations. Bidder will assist and furnish updated bulk storage permit to town.

Price for One New 3000gal Petro Hopper Installed: \$ 72,499.00

JUS-SAR Fuel  
Company Name

845-791-8900  
Telephone

BOBBY MADES  
Contact Person(s)

884 Old Rt 17 / PO Box 289  
Address

OWNER, PRESIDENT  
Title(s)

HARRIS NY 13742  
City, State, Zip

Billy M. Pres  
Signature

9/28/23  
Date

\*\*\*\*\*Do not write below this line\*\*\*\*\*

ACCEPTED [ ] Date: \_\_\_\_\_

REJECTED [ ]

Comments:

\_\_\_\_\_

\_\_\_\_\_

Signature

#5A

**September 19, 2023**

**Surplus Inventory**

Lawn Mower – Ariens 55 – VIV55501001A

Pressure Washer – Honda 2600Psi – XR2600 – GC160 – 0000648848

Generator – Briggs & Stratton – HM2800084 – Model #EH400HD

Weed Wacker – STIHL – FS106 – 17091399

Weed Wacker – STIHL – FS76 – 24865102

Weed Wacker – STIHL Plus - FS76 – N/A

Welder – Kohler16 Magnum – 86WS10461

DR Trimmer – Briggs & Stratton – 725EXI – TR450728MN – Serial #3003371473

#5B

**September 19, 2023**

**Auction**

John Deere Gator 625i – Model #625GASXUV – IM0625GSLCM044210

Zero Turn 997ZTrak – 2008 – 997Z-DS-60SD – 20180018 – TC997SB030126

Ram 1500 – 2016 1C6RR7XT0GS420532 – MDH070911 911AA



FYI



**SULLIVAN COUNTY DEPARTMENT OF PUBLIC HEALTH**

**FREE**

**RABIES CLINIC**

*FOR DOGS, CATS, AND FERRETS*



Public Health  
Prevent. Promote. Protect.  
Sullivan County  
Department of Public Health

**Wednesday, October 11, 2023 6:00-7:30 PM**  
**Town of Thompson Monticello Firehouse**  
**23 Richardson Ave.**  
**Monticello, NY**

- ◆ All pet owners must clean up after their pets.
- ◆ All pets must be at least 3 months old.
- ◆ All pets must be in a carrier or on a leash.
- ◆ Aggressive dogs should be muzzled to prevent any biting incidents.
- ◆ Bring proof of prior rabies vaccination to receive a 3-year vaccination.
- ◆ If you do not have proof of prior rabies vaccination, your pet will receive a 1-year vaccination.
- ◆ Social distancing guidelines must be followed. Please remain at least 6 feet apart.

**Sullivan County Residents Only!**

- ◆ Please bring photo ID as proof of Sullivan County Residency.

**APPOINTMENTS ARE REQUIRED!**

Pre-registration of ALL animals is required. To pre-register, visit:

<https://tinyurl.com/y575p832>

Or scan:



If you are unable to pre-register, or have any additional questions, please call:

Sullivan County  
Department of Public Health  
at : 845-292-5910, Ext. 0.

Support  
TEAM SULLIVAN

**JOIN US  
FOR THE  
ALZHEIMER'S WALK  
AT  
HURLEYVILLE RAIL TRAIL  
OCTOBER 14<sup>TH</sup> 10 AM**

FYI<sub>2</sub>