

JOIN ZOOM MEETING:<https://us02web.zoom.us/j/85882059271>

+1-646-558-8656

**TOWN OF THOMPSON
-Regular Meeting Agenda-****TUESDAY, MAY 05, 2020****7:00 PM MEETING******DUE TO THE COVID-19 PANDEMIC THIS MEETING WILL BE STREAMED LIVE ON ZOOM****TO JOIN: PLEASE SEE OUR TOWN WEBSITE: WWW.TOWNOFTHOMPSON.COM****OR FACEBOOK @ TOWN OF THOMPSON NY****CALL TO ORDER****ROLL CALL****PLEDGE TO THE FLAG****APPROVAL OF PREVIOUS MINUTES:** April 21st, 2020 Regular Town Board Meeting
April 30th, 2020 Reconvened Town Board Meeting**PUBLIC COMMENT****CORRESPONDENCE:**

- **Susan Cockburn, Asst. Engineer, NYS DEC:** Letter dated 04/20/20 to Supervisor Rieber Re: Emerald Green Lake Louise Marie WWTP, SPDES Permit #NY0035645 – Schedule of Compliance Extension for Chlorine Total Residual
- **U.S. Environmental Protection Agency Region 2:** Letters dated 04/24/20 to Supervisor Rieber Re: Notice of Significant Non-Compliance – Emerald Green Lake Louise Marie Sewer District, SPDES Permit #NY0035645–Chlorine Total Residual
- **Pamela Gendron, P.E., Regional Traffic Operations Engineer, NYS DOT:** Letter dated 03/04/20 to Mr. Edward McAndrew, P.E., Commissioner, SC DPW Re: Revised Orders for Speed Limit Reduction Request – Resorts World Drive (TH 206) and Joyland Road (TH 60)
- **Chris Borne, Environmental Specialist I, NYS DOT:** Letter dated 03/11/20 to Mr. Basil Seggos, Commissioner, NYS DEC Re: Notice of Environmental Determination (SEQRA Determination of No Significant Effect (DONSE)) for PIN 9TCR.19, Culvert Replacement Project in Town of Thompson, Guilford, Meredith, Preston and Delhi in Sullivan, Chenango and Delaware Counties.
- **Ben Itzkowitz, Public Adjuster of B Adjusters:** Letter dated 04/21/20 to Town of Thompson Re: Town of Thompson Highway Department Garage Structure Fire, Date of Loss: 09/17/2019 – Final Supplemental Payment for Contents Damage of \$11,483.78
- **K.W. REESE, INC. on behalf of NYSEG:** Letter dated 04/08/20 to Town of Thompson Re: Routine Vegetation Maintenance including tree trimming, danger tree removal, brush cutting, herbicide treatment and/or mowing in the area of Town of Thompson
- **NYS Dept. of Taxation and Finance:** Check #07783238, Dated: 04/23/20 in the amount of \$548,966.25 – NYS Gaming Commission for Resorts World Catskill Casino Distribution 4th Quarter Payment

AGENDA ITEMS:**1) APPROVE SULLIVAN RENAISSANCE 2020 MUNICIPAL GRANT PROGRAM GRANT ADDENDUM****2) REPORT ON RECONVENED TOWN BOARD MEETING RE: TOWN INSURANCE COVERAGE RENEWAL EFFECTIVE 05/01/2020****3) DISCUSS & AUTHORIZE SERVICES OF STENOGRAPHER FOR TRANSCRIPTION OF MEETINGS**

4) DEPT. OF PARKS & RECREATION: ESTABLISH DATE FOR BID OPENING FOR THURSDAY, 05/21/2020 AT 2PM – ASBESTOS REMOVAL & BUILDING DEMOLITION AT CAMP IDA PARK (F/K/A CAMP JENED PROPERTY)

5) HIGHWAY DEPT.: REVIEW & APPROVE BIDS – SPRAY PAVER INSTALLED BONDED WEARING COURSE (VARIOUS)

6) BILLS OVER \$2,500.00

7) BUDGET TRANSFERS & AMENDMENTS

8) ORDER BILLS PAID

9) UPDATE: CORONAVIRUS (COVID-19) PANDEMIC

OLD BUSINESS

NEW BUSINESS

REPORTS: SUPERVISOR, COUNCILMEN, & DEPARTMENT HEADS

PUBLIC COMMENT

ADJOURN



Town Supervisor
William J. Rieber, Jr.

Town Board Members
Deputy Supervisor Scott Mace
John Pavese
Melinda Meddaugh
Ryan Schock

**LEGAL NOTICE
TOWN OF THOMPSON
TOWN BOARD MEETINGS
VIDEO CONFERENCING**

PLEASE TAKE NOTICE, that effective immediately and based upon notices and health advisories issued by Federal, State and Local officials related to the COVID-19 virus, the Town Board will not be holding in-person meetings. Until further notice, all future Town Board meetings (including Public Hearings) will be held via videoconferencing, as permitted by the NYS Open Meetings Law. Due to public health and safety concerns, the public will not be permitted to attend at the remote locations where the Town Board members will be situated. The public, however, will be able to fully observe the videoconferencing meeting and comment at appropriate times. To the extent internet access is not available; the public can attend via telephone by dialing (+1-646-558-8656). The Town Board's agenda is available online in advance of the meetings at www.townofthompson.com and the public can email written comments or questions by 4:30 pm on the day of the meeting addressed to supervisor@townofthompson.com. Any member of the public who has questions should contact the Secretary to the Supervisor in advance of the meeting at 845-794-2500 x306 or supervisor@townofthompson.com. Anyone having difficulty connecting to the meeting should contact Zoom for IT assistance during the meeting.

PLEASE TAKE FURTHER NOTICE, that any Executive Session of the board will be initiated with the Board first convening on the public videoconferencing site, adopting a motion to go into Executive Session and then returning to the public videoconferencing site once the Executive Session has concluded.

PLEASE TAKE FURTHER NOTICE, that the Town Board Meeting of Tuesday, May 05, 2020 at 7:00 PM can be accessed at:

Join Zoom Meeting

<https://us02web.zoom.us/j/85882059271>

Dial by your location

+1 646 558 8656 US (New York)

Meeting ID: 858 8205 9271

C

NEW YORK STATE DEPARTMENT OF ENVIRONMENTAL CONSERVATION

Region 3 Main Office
21 South Putt Corners Road, New Paltz, NY 12561-1620
P: (845) 256-3000 | F: (845) 255-3042
www.dec.ny.gov

April 20, 2020
Town of Thompson
4052 Route 42
Monticello, N. Y. 12701

Re: SPDES # NY 0035645
Town of Thompson, Emerald Green-Lake Louise Marie WWTP
Schedule of Compliance – Chlorine Residual

Dear Mr. Rieber,

The town has requested an extension of time to June 28, 2020 for submission of the Engineering Report Plans/Specifications to meet the final effluent limit for Total Residual Chlorine.

The New York Code of Rules and Regulations (NYCRR) Part 750-2.1 (i), General Provisions of SPDES Permit states. "The permittee shall furnish to the Department, within a reasonable time as set forth in the Department request, any information that the Department may request to determine whether cause exists for modifying, suspending. Or revoking a SPDES permit. Or to determine compliance with the permit."

The department has determined to utilize its enforcement discretion and not pursue enforcement for a violation of NYCRR Pat 750-2.1 (i) provided the submissions are made by the above dates.

Should you have any questions, please do not hesitate to contact me at (845) 256-3162 or susan.cockburn@dec.ny.gov.

Sincerely,

Susan Cockburn
Asst. Engineer

cc: Town Board
Mary Beth Bianconi, Delaware Engineering
Michael Messenger, Superintendent of Thompson Sewer and Water
Paul Buist, Assistant Engineer, NYSDEC



UNITED STATES ENVIRONMENTAL PROTECTION AGENCY
REGION 2
290 BROADWAY
NEW YORK, NY 10007-1866

Dear Permittee:

I hope this letter finds you, your family and your colleagues all doing well during these difficult times. Attached please find a formal notice from my office addressing concerns with the operation of your wastewater treatment system during a period prior to the current situation.

Please know that as part of our mission, we are obliged to provide this notice to move your community in a direction that ensures your system is operating in a manner consistent with state discharge limits to meet the goal of being protective of public health and the environment.

With that said, we are also asking you to help us understand why your system is not meeting the discharge standards, so we can better understand how EPA and our state partners can assist in helping you improve the situation. We understand that the current situation due to the global pandemic may add additional challenges to compliance due to various factors including staffing impacts. We invite you to explain any issues you are currently experiencing; but know that our focus is on past violations.

Thank you for your kind attention to this matter. We look forward to your response as outlined in the attached notice of significant non-compliance. If you have any questions, or if there is anything we can help you with, please let me know.

Sincerely,

A handwritten signature in black ink, appearing to read "Peter D. Lopez".

Peter D. Lopez
Regional Administrator

Enclosure

Internet Address (URL): <http://www.epa.gov>

Recycled/Recyclable • Printed with Vegetable Oil Based Inks on Recycled Paper (Minimum 30% Postconsumer)



UNITED STATES ENVIRONMENTAL PROTECTION AGENCY
 REGION 2
 290 BROADWAY
 NEW YORK, NY 10007-1866

April 24, 2020

Mr. William J. Rieber Jr., Supervisor
 Thompson (T)
 4052 St Route 42, Town Hall
 Monticello, NY 12701
 supervisor@townofthompson.com

**Re: Notice of Significant Non-Compliance
 Emerald Green/Lake Louise Marie S&W D
 SPDES Tracking ID No. NY0035645**

Dear Supervisor Rieber:

I hope this letter finds you, your family and your colleagues all doing well. This notice is concerning the operation of your wastewater treatment system during a period prior to the current COVID-19 situation. Based on data reported to the United States Environmental Protection Agency (EPA) and reflected in the EPA's national data system, your facility is currently in **Significant Non-Compliance (SNC)** due to the following exceedance(s) of the effluent limit(s) in your New York State Department of Environmental Conservation (NYSDEC) State Pollutant Discharge Elimination System (SPDES) permit, NY0035645:

Violation Date(s)	Outfall(s)	Parameter(s)
9/2019	001-A	Chlorine, total residual
10/2019	001-A	Chlorine, total residual

This notice is strictly addressing SNC effluent violation reporting over the last two (2) quarters and may not include all schedule or other effluent violations.

As one of the Agency's Strategic Measures, EPA is currently working with all state programs, including NYSDEC, to reduce the number of facilities in SNC. Our first step in this process as it relates to your facility is to make sure you are aware of your violations and to ask for explanations of why the violations are occurring and what you are doing to correct the violations and return to compliance with your permit. For additional information on SNC, please see:

<https://www.epa.gov/enforcement/memorandum-revision-npdes-significant-noncompliance-snc-criteria-address-violations-non> or <https://echo.epa.gov/resources/general-info/echo-faq>.

Therefore, we are asking you to respond to EPA in writing within **thirty (30) days**, describing the cause(s) of the violations, as well as the actions you have taken or will take to address the violations. Under 6 NYCRR Part 750-2.7(e), you may have provided a Report of Noncompliance Event to NYSDEC, which you may use as a guide for your response with additional details or updates appended. However, we understand if you need more time, just let us know.

Please submit your response to me electronically at mckenna.douglas@epa.gov. Please also submit a copy of your response to the NYSDEC Regional Office (Acting Regional Water Engineer, NYSDEC Region 3, 21 South Putt Corners Rd., New Paltz, NY 12561) and to the NYSDEC Central Office (Edward Hampston, Director, Bureau of Water Compliance Programs, 625 Broadway, Albany, NY 12233-0001, or electronically to edward.hampston@dec.ny.gov). If you believe the data was reported in error, please provide an appropriate amendment to your Discharge Monitoring Reporting (DMR).

Please also note that this is a separate initiative by EPA in working with state programs to address SNC. Your response to this notice does not relieve you of any requirements established by NYSDEC, your permit, or Part 750 regulations, and you must continue to comply with these requirements. If you have been working with NYSDEC to address these violations, please continue to do so, or you may wish to re-evaluate your previous response. NYSDEC may take separate compliance or enforcement action regarding these violations, or EPA may take further action in consultation with NYSDEC.

We understand that the current situation due to the Global Pandemic may add additional challenges to compliance due to various factors including staffing impacts. We welcome you to explain any issues you are currently experiencing; but know that our focus is on past violations. Additionally, if COVID-19 has impacted your ability to perform required monitoring, sampling and reporting, please visit the NetDMR COVID-19 Information Page at <https://netdmr.zendesk.com/hc/en-us/articles/360041746691-COVID-19-Information-Page> for guidance.

Should you have any questions concerning this letter, please contact your Regional NYSDEC office, or feel free to contact Mr. Patrick Whalen of my staff at (212) 637-4290 or whalen.patrick@epa.gov. If you would like to review your facility's compliance history in EPA's data system you can enter and search with your permit number at: <https://echo.epa.gov>. I wish you the best during these difficult times, and if there is anything you feel we can help you with, please let us know.

Sincerely,



Douglas McKenna, Chief
Water Compliance Branch

cc: Edward Hampston, P.E., Director, Bureau of Water Compliance Programs,
Division of Water, NYSDEC (pdf)
Michael G. Messenger, Superintendent of Water and Sewer, Town of Thompson (pdf)



**Department of
Transportation**

ANDREW M. CUOMO
Governor

MARIE THERESE DOMINGUEZ
Acting Commissioner

NICOLAS A. CHOUBAH, P.E.
Regional Director

March 4, 2020

Mr. Edward McAndrew, P.E.
Commissioner
Sullivan County Government Center
100 North Street
P.O. Box 5012
Monticello, New York 12701

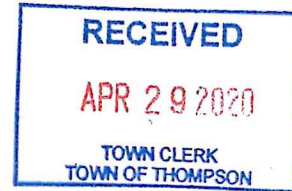

Dear Commissioner McAndrew:

**Re: REQUEST FOR SPEED LIMIT REDUCTION
RESORTS WORLD DRIVE (TH 206)
TOWN OF THOMPSON, SULLIVAN COUNTY**

As we discussed on March 4, 2020, the attached orders have been revised to the following:

Notice of Order 11 48.20 (ab) establishes 30 MPH on Joyland Road (TH 60) between Resorts World Drive (TH 206) and CR 173, a distance of 1.1 +/- miles.

Notice of Order 11 48.20 (be) establishes 40 MPH on Resorts World Drive (TH 206) between Kiamesha Lake Road, CR 109, and Thompson Road, a distance of 1.5 +/- miles.

Notice of Order 11 48.20 (bf), as enclosed, establishes 30 MPH on Resorts World Drive (TH 206) between Thompson Road and Joyland Road (TH 60) a distance of 0.3 +/- mile.

Notice of Order 11 48.20 (bg) establishes 40 MPH on Resorts World Drive (TH 206) between Joyland Road (TH 60) and the intersection of the NYS Route 17 (future I-86) westbound on/off ramps and Cimarron Rd (TH 105) a distance of 1.5 +/- miles.

The Town of Thompson will be responsible for installing the appropriate signs to reflect these speed limits. The new speed limit signs must be installed in accordance with Title 17B of the New York State official Compilation of Rules and Regulations (New York State Supplement to the National Manual on Uniform Traffic Control Devices). In addition, the Town of Thompson may want to review the existing warning signs.

If you have any questions, please feel free to contact me at (607) 721-8072.

Sincerely,



Pamela Gendron, P.E.
Regional Traffic Operations Engineer

PG
enclosures

c: Marilee J. Calhoun, Town Clerk, Town of Thompson
Dermot P. Dowd, L.S., Civil Engineer

bc: TESL #0919 0008
Mail log #913

STATE OF NEW YORK - DEPARTMENT OF TRANSPORTATION
TRAFFIC OPERATIONS BUREAU

NOTICE OF ORDER

STUDY NO.: 919 0008

FILE: 48.20 -

TROOP: F

THE DEPARTMENT OF TRANSPORTATION HAS FILED AN ORDER WITH THE SECRETARY OF STATE WHEREBY:

SECTION: 11 48.20 SUBDIVISION: (bg) PARAGRAPH: _____

OF THE DEPARTMENT'S REGULATIONS IS ADDED AMENDED to read as follows: REPEALED

40 MPH on Resorts World Drive, TH 206, between Joyland Road, TH 60, and the Route 17, future I 86 westbound on/off ramps, Cimarron Road, TH 105, a distance of 1.5 +/- miles.

The above order will be effective upon the installation, modification or removal of the necessary traffic control device (s) required by and conforming to the State Manual of Uniform Traffic Control Devices.

1/23/2020 APPROVED BY: *Anthony Signorelli* Regional Traffic Engineer
(DATE) (SIGNATURE) (TITLE)

DESCRIPTION:

COUNTY: Sullivan

LOCALITY Town of Thompson

OTHER RELATED ACTIONS NONE

(Identify)

cc: CITY

VILLAGE

TOWN

COUNTY SUPT.

SHERIFF

STATE POLICE

PERMITTEE

_____ POLICE DEPARTMENT

REGION 9 TRAFFIC ENGINEER

OTHER _____
(Specify)

STATE OF NEW YORK - DEPARTMENT OF TRANSPORTATION
TRAFFIC OPERATIONS BUREAU

NOTICE OF ORDER

STUDY NO.: 919 0008

FILE: 48.20 -

TROOP: F

THE DEPARTMENT OF TRANSPORTATION HAS FILED AN ORDER WITH THE SECRETARY OF STATE WHEREBY:

SECTION: 11 48.20 SUBDIVISION: (bf) PARAGRAPH: _____

OF THE DEPARTMENT'S REGULATIONS IS ADDED AMENDED to read as follows: REPEALED

30 MPH on Resorts World Drive, TH 206, between Thompson Road and Joyland Road, TH 60, a distance of 0.3 +/- mile.

The above order will be effective upon the installation, modification or removal of the necessary traffic control device (s) required by and conforming to the State Manual of Uniform Traffic Control Devices.

3/4/2020 APPROVED BY: *Anthony Signorelli* Anthony Signorelli, P.E. Regional Traffic Engineer
(DATE) (SIGNATURE) (TITLE)

DESCRIPTION:

COUNTY: Sullivan

LOCALITY Town of Thompson

OTHER RELATED ACTIONS NONE

(Identify)

cc: CITY

VILLAGE

TOWN

COUNTY SUPT.

SHERIFF

STATE POLICE

PERMITTEE

_____ POLICE DEPARTMENT

REGION 9 TRAFFIC ENGINEER

OTHER _____

(Specify)

STATE OF NEW YORK - DEPARTMENT OF TRANSPORTATION
TRAFFIC OPERATIONS BUREAU

NOTICE OF ORDER

STUDY NO.: 919 0008

FILE: 48.20 -

TROOP: F

THE DEPARTMENT OF TRANSPORTATION HAS FILED AN ORDER WITH THE SECRETARY OF STATE WHEREBY:

SECTION: 11 48.20 SUBDIVISION: (be) PARAGRAPH: _____

OF THE DEPARTMENT'S REGULATIONS IS ADDED AMENDED to read as follows: REPEALED

40 MPH on Resorts World Drive, TH 206, between Kiamesha Lake Road, CR 109, and Thompson Road, a distance of 1.5 +/- miles.

The above order will be effective upon the installation, modification or removal of the necessary traffic control device (s) required by and conforming to the State Manual of Uniform Traffic Control Devices.

3/4/2020

APPROVED BY:

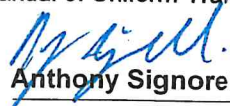

Anthony Signorelli, P.E.

Regional Traffic Engineer

(DATE)

(SIGNATURE)

(TITLE)

DESCRIPTION:

COUNTY: Sullivan

LOCALITY Town of Thompson

OTHER RELATED ACTIONS NONE

(Identify)

cc: CITY

VILLAGE

TOWN

COUNTY SUPT.

SHERIFF

STATE POLICE

PERMITTEE

_____ POLICE DEPARTMENT

REGION 9 TRAFFIC ENGINEER

OTHER _____
(Specify)

STATE OF NEW YORK - DEPARTMENT OF TRANSPORTATION
TRAFFIC OPERATIONS BUREAU

NOTICE OF ORDER

STUDY NO.: 919 0076

FILE: 48.20 -

TROOP: F

THE DEPARTMENT OF TRANSPORTATION HAS FILED AN ORDER WITH THE SECRETARY OF STATE WHEREBY:

SECTION: 11 48.20 SUBDIVISION: (ab) PARAGRAPH: _____

OF THE DEPARTMENT'S REGULATIONS IS ADDED AMENDED to read as follows: REPEALED

30 MPH on Joyland Road, TH 60, between Resorts World Drive, TH 206, and CR 173, a distance of 1.1 +/- mile.

The above order will be effective upon the installation, modification or removal of the necessary traffic control device (s) required by and conforming to the State Manual of Uniform Traffic Control Devices.

3/4/2020

APPROVED BY:

Anthony Signorelli

Anthony Signorelli, P.E.

Regional Traffic Engineer

(DATE)

(SIGNATURE)

(TITLE)

DESCRIPTION:

COUNTY: Sullivan

LOCALITY Town of Thompson

OTHER RELATED ACTIONS NONE

(Identify)

cc: CITY

VILLAGE

TOWN

COUNTY SUPT.

SHERIFF

STATE POLICE

PERMITTEE

POLICE DEPARTMENT

REGION 9 TRAFFIC ENGINEER

OTHER

(Specify)



**Department of
Transportation**

ANDREW M. CUOMO
Governor

MARIE THERESE DOMINGUEZ
Commissioner

NICOLAS A. CHOUBAH, P.E.
Regional Director

March 11, 2020

Mr. Basil Seggos, Commissioner
New York State Department of Environmental Conservation
625 Broadway
Albany, New York 12233-1011

Dear Commissioner Seggos:

**RE: NOTICE OF ENVIRONMENTAL DETERMINATION
PIN 9TCR.19, CULVERT REPLACEMENT PROJECT
TOWNS OF THOMPSON, GUILFORD, MEREDITH, PRESTON,
AND DELHI
SULLIVAN, CHENANGO, AND DELAWARE COUNTIES**

I am transmitting to you for your files one copy of the State Environmental Quality Review Act (SEQRA) Determination of No Significant Effect for the referenced project.

I am sending this document to fulfill the Notice and Filing Requirements for New York State Department of Transportation projects that are determined to be SEQRA Non-Type II under 17 NYCRR Part 15. Please see the attached determination for more information.

If you have questions or concerns about this project please direct them to Jayme Szili, Project Manager, at (607) 721-8346.

Sincerely,

Chris Borne
Environmental Specialist I

CB/at

Enclosure

cc: Matthew Marko, Regional Dir., NYSDEC Region 7
Keith Goertz, Regional Dir., NYSDEC Region 4
Kelly Turturro, Regional Dir., NYSDEC Region 3
Chenango County, Board of Supervisors

Delaware County, Board of Supervisors
Sullivan County Legislature
Town of Thompson
Town of Preston
Town of Guilford
Town of Meredith
Town of Delhi
D. Hitt, Environmental Services Bureau, 4th Floor, POD 41
File (e)

SEQRA DETERMINATION OF NO SIGNIFICANT EFFECT (DONSE)

NOTICE OF ENVIRONMENTAL DETERMINATION
NEW YORK STATE DEPARTMENT OF TRANSPORTATION
PROJECT IDENTIFICATION NO. 9TCR19
CULVERT REPLACEMENT PROJECT
TOWNS OF THOMPSON, GUILFORD, MEREDITH, PRESTON, AND DELHI,
SULLIVAN, CHENANGO, AND DELAWARE COUNTIES

This notice is a "negative declaration" for the purposes of Article 8 of the New York State Environmental Conservation Law. The New York State Department of Transportation (NYSDOT), being the agency having principle responsibility for carrying out or approving the project, is the lead agency pursuant to Part 15 of Title 17 of the Official Compilation of Codes, Rules and Regulations of the New York State (17 NYCRR Part 15).

This project involves the replacement of 5 culverts spread across Chenango, Delaware, and Sullivan Counties. This project is a NEPA Class II Action (Categorical Exclusion) and because the project does not meet the criteria for SEQRA Type II projects/actions found in 17 NYCRR Part 15.14, Section (d) (6) it is considered a SEQRA Non-Type II action.

In consultation with the State Historic Preservation Office and the Federal Highway Administration, NYSDOT determined that this project will not have a significant effect on the environment because the proposed project will not have any of the effects listed in NYCRR Part 15.11 "Criteria for Determining Whether an Action May Have a Significant Effect on the Environment". This determination is based upon the findings and considerations noted in the project's Final Design Report including the following:

This project will require the acquisition of a property easement involving one National Register for Historic Places (NR) listed property: the Sherwood Family Estate (02NR04914). An estimated 500 sq. ft. property easement from the 221 acre NR listed Sherwood Family Estate will be required for the work involving C963003 on NY Rte 10. This small acquisition will have No Adverse Effect upon the National Register property. FHWA and SHPO have concurred in writing with this determination.

Further information on this project may be obtained from:

Jayne Szili, Project Manager
New York State Department of Transportation
Region 9
44 Hawley Street
Binghamton, NY 13901
607-721-8346

Nicolas A. Choubah, P.E., Regional Director

10-7-19
Date

B Adjusters

04/21/2020

*Town of Thompson
33 Jefferson Street
Monticello, NY, 12701*

*DOL-09/17/2019
Claim#- TNT- 0156375*

Attached you will find the final supplemental payment for the Contents damage of your claim. please note that our fee has not been paid directly as seen in the invoice attached.

If you should have any further questions feel free to contact our office.

Thank you, and it was a pleasure doing business with you!

Respectfully,

B Adjusters



***Ben Itzkowitz
Public Adjuster***

AIC - Programs
 On Behalf Of: Argonaut Insurance Company
 Handled By:
 Contact us at : (833) 240-4128

JPMorgan Chase Bank, N.A.
 Dallas, TX

Check Number: **26305**

Policy/Certificate: PE 4631948-05
 Insured: Town of Thompson

88-88
 1113

Source: FH-TNE

Claim Number: TNT-0156375
 Date of Loss: 09/17/2019
 Claimant: Town of Thompson

Period Covered: 2020-03-10 to 2020-03-10
 Adjuster: brian.jarrelly

Date: **03/11/2020**

Void After 180 Days

Amount: **\$11,483.78**

[Signature]
 AUTHORIZED REPRESENTATIVE

PAY **Eleven Thousand Four Hundred Eighty-Three Dollars And Seventy-Eight Cents****

PAY TO THE ORDER OF **TOWN OF THOMPSON AND BEN ITZKOWITZ**

PAYEE ADDRESS FOR **Ben Itzkowitz
 P.O. Box 716
 Harriman, NY 10926
 Supplemental pymt for Contents dmg in fire loctd@33 Jefferson NY**



DETACH BEFORE CASHING (Retain stub for your records.)

Pay To: **TOWN OF THOMPSON AND BEN ITZKOWITZ**

Payee: **AIC - Programs**

For: **Supplemental pymt for Contents dmg in fire loctd@33 Jefferson NY**

Contact us at : (833) 240-4128

Check Number: **26305**
 Issued: **03/11/2020**

Claim Number	Claimant Name	Invoice	Paid Amt	Billed Amt	Policy/Certificate	DT of Loss	Period Covered
Type Pay	Pymt Desc	Adjuster		FEIN/SSNO	Insured Name		Treaty Name
NT-0156375	Town of Thompson	brian.jarrelly	11,483.78	11,483.78	PE 4631948-05	09/17/2019	2020-03-10 to 2020-03-10
	Property				Town of Thompson		
		Total	11,483.78	11,483.78			

Mail To: **Town of Thompson and Ben Itzkowitz
 Ben Itzkowitz
 P.O. Box 716
 Harriman NY 10926**

REESE

April 8, 2020

**TOWN OF THOMPSON
4052 ROUTE 42
MONTICELLO NY 12701**

To Whom It May Concern,

This notice is to make affected property owners aware that **K.W. REESE, INC.** has been **contracted by NYSEG** to perform routine vegetation maintenance, which may possibly include, tree trimming, danger tree removal, brush cutting, herbicide treatment and/or mowing, of power lines in your area. We are hereby notifying all property or adjacent property owners of tree and vegetation maintenance to be performed in the near future.

If herbicide treatment application is called for, K.W. REESE, INC. may be using one or more of the following herbicides listed below. The website for the herbicide label is listed below if you wish to have more information on the herbicide.

GARLON 4 ULTRA

https://natseed.com/pdf/Garlon%204%20Specialty%20Herbicide_Label.pdf

POLARIS

<https://www.cdms.net/ldat/ld8ID004.pdf>

VASTLAN

https://s3-us-west-1.amazonaws.com/agrian-cg-fs1-production/pdfs/Vastlan_Label1h.pdf

MILESTONE

https://s3-us-west-1.amazonaws.com/agrian-cg-fs1-production/pdfs/Milestone1d_Label.pdf

ESCORT

<http://www.cdms.net/ldat/ldCFM000.pdf>

The cost of the work is paid by NYSEG. There is no cost to the property owner. K.W. REESE, INC. may start this work within two weeks from the date of this letter, weather permitting.

If you have any questions or concerns regarding the maintenance work, please contact James Gardner at **(717) 860-7287**.

Thank you for your cooperation.
NYSEG

K . W . R E E S E I N C O R P O R A T E D
9486 BUCHANAN TRAIL WEST • P.O. BOX 298 • MERCERSBURG, PENNSYLVANIA 17236
PHONE (717) 328-5211 • FAX (717) 328-9541

State of New York

A

REMITTANCE ADVICE for CHECK NO. 07783238

NOTICE: To access remittance information on any one of your NYS payments, visit <https://esupplier.sfs.ny.gov/>

Agency Code and Description	Tele Inquiry No	Voucher No	Payee Reference/Invoice No	Ref/Inv Date	Payment Amount
GAM01 NYS Gaming Commission		00025568	Resorts Distrib 4th qrt 19/20	04/20/20	548,966.25

GOV'T ENTITIES, VENDORS, NOT-FOR-PROFITS:

Non-Negotiable Check Total \$548,966.25

Go to <http://www.osc.state.ny.us/epay/index.htm> for Electronic Payments information

DETACH HERE BEFORE CASHING ↓

PLEASE CASH WITHIN 180 DAYS

THIS DOCUMENT HAS MULTIPLE SECURITY FEATURES INCLUDING HEAT SENSITIVE, COLOR CHANGING INK ON THE BACK OF THE DOCUMENT

09870974

State of New York

Check No. 07783238

\$548,966.25

DEPARTMENT OF TAXATION AND FINANCE
DIVISION OF THE TREASURY

29-55
213

A

APRIL 23, 2020

GAM01

KNOW YOUR ENDORSER

Pay to the Order of: **THOMPSON TOWN OF**

\$548,966.25

Thomas P. DiNapoli
Thomas P. DiNapoli
State Comptroller

KeyBank N.A.

Michael R. Schmidt
Michael R. Schmidt
Commissioner, Dept. of Taxation and Finance

STATE OF NEW YORK
DEPARTMENT OF TAXATION AND FINANCE
DIVISION OF THE TREASURY
PO BOX 22119
ALBANY, NEW YORK 12201-2119



ZIP 12207 \$ 000.00
02 1W
0001404347 APR 28

THOMPSON TOWN OF
4052 STATE ROUTE 42
MONTICELLO NY 12701-3221



**Town of Thompson
General Ledger Detail Transaction Report
Fiscal Year 2019**

Account Number	Account Description	AM	Journal Date	Type/Num	Reference	Budget Amount	Debit	Credit	Enc/Liq	Act Exp
A000.3016.000	CASINO LICENSING FEE & GAMING REVENUES									
	YEAR FORWARD BALANCE									
	Rebuild BY Journal	1	1/1/2019	BY1-1	Total	(\$1,200,000.00)	\$0.00	\$0.00	\$0.00	\$0.00
	Resorts World Catskills - Jan-March 2019	4	4/25/2019	CR105908	NYS ck#07091612	\$0.00	\$0.00	\$622,256.35	\$0.00	\$0.00
	RW Catskills Quarterly pmt April - June	8	8/1/2019	CR106406	NYS ck#07300967	\$0.00	\$0.00	\$622,256.35	\$0.00	(\$622,256.35)
	RW Catskills Quarterly pmt	10	10/30/2019	CR106830	NYS Ck#07469521	\$0.00	\$0.00	\$726,029.00	\$0.00	(\$726,029.00)
	Budget Transfers & Amendments - Town Board Meeting 11/06/19	11	11/6/2019	BE106847	RW Catskills	\$0.00	\$0.00	\$793,251.97	\$0.00	(\$793,251.97)
	Year End Revenue Accruals	12	12/31/2019	JE107271	Casino 4th Qtr	\$0.00	\$0.00	\$0.00	\$0.00	\$0.00
	Budget Transfers & Amendments - Town Board Meeting 02/19/2020	12	12/31/2019	BE107295		(\$588,175.00)	\$0.00	\$0.00	\$0.00	\$0.00
	YTD Total for A000.3016.000				CASINO LICENSING FEE & GAMING REVENUES	(\$2,788,175.00)	\$0.00	\$646,640.61	\$0.00	(\$646,640.61)
	Total for Fund A000					(\$2,788,175.00)	\$0.00	\$2,788,177.93	\$0.00	(\$2,788,177.93)
	Grand Total					(\$2,788,175.00)	\$0.00	\$2,788,177.93	\$0.00	(\$2,788,177.93)



Town of Thompson
General Ledger Detail Transaction Report
Fiscal Year 2020

Account Number	Account Description	AM	Journal Date	Type/Num	Reference	Budget Amount	Debit	Credit	Enc/Liq	Act Exp
A000.3016.000	YEAR FORWARD BALANCE									
	Rebuild BY Journal	1	1/1/2019	BY1-1		(\$1,500,000.00)	\$0.00	\$0.00	\$0.00	\$0.00
					Mth 1		\$0.00	\$0.00	\$0.00	\$0.00
					Total		\$0.00	\$0.00	\$0.00	\$0.00
	RW Catskills Quarterly pmt	4	4/27/2020	CR107631	NYS ck#07783238	\$0.00	\$0.00	\$548,966.25	\$0.00	\$0.00
					Mth 4		\$0.00	\$548,966.25	\$0.00	(\$548,966.25)
					Total		\$0.00	\$548,966.25	\$0.00	(\$548,966.25)
	YTD Total for A000.3016.000				CASINO LICENSING FEE & GAMING REVENUES	(\$1,500,000.00)	\$0.00	\$548,966.25	\$0.00	(\$548,966.25)
	Total for Fund A000					(\$1,500,000.00)	\$0.00	\$548,966.25	\$0.00	(\$548,966.25)
	Grand Total					(\$1,500,000.00)	\$0.00	\$548,966.25	\$0.00	(\$548,966.25)



Building beautiful, healthy, active communities

AI
#1

**SULLIVAN RENAISSANCE
2020 MUNICIPAL GRANT PROGRAM
GRANT ADDENDUM**

TOWN OF THOMPSON

Intended Use of the Grant

The Town of Thompson will complete a variety of projects in the area of caring for public spaces including but not limited to:

- Beautification and maintenance of Route 17W Exit 105 W, including replacing the current landscaping
- Installation of new "Welcome to the Town of Thompson" sign at Route 42 and replace 10 existing Town entrance signs which will incorporate the Town's new logo
- Maintenance of Rock Hill Murals which need to be repainted
- Maintenance of existing Town gardens and public spaces including the two Dove locations, garden at Route 42 "Welcome" sign, Town Hall, and several gardens at Town Park

Grant Package

The following Grant Package has been awarded for the project described above:

- Grant Amount: \$15,000
- Flower Dollars: \$1,000 (expire July 6th)
- Bulb Dollars: \$500

Grant Conditions

- Increase the size of the proposed plant containers at both Doves and work with Sullivan Renaissance Horticultural team to discuss landscaping plans
- Address past and current code enforcement initiatives

Additional Recommendations

- Verify placement of stepping stones leading to Dove
- Discuss long-term plans for mural maintenance with Sullivan Renaissance

Outstanding Phase II Grants

- Won \$250,000 2019 Golden Feather

Grant Received by: Sign Name: _____ Date: _____
Print Name: _____



Building beautiful, healthy, active communities

April 20, 2020

William Rieber, Supervisor
Town of Thompson
4052 State Route 42
Monticello, NY 12701

Sandra Gerry, Chair

STEERING COMMITTEE

Leni Binder
Daniel Briggs
Kathy Davidoff
Gay Donofrio
Cora Edwards
John Evans
Hon. Josephine V. Finn
Foster Supply Hospitality
Danielle Gaebel
Ruby Gold
Katrina Graby
Jacquie Leventoff
Dali Levy
Barry Lewis
Lorraine Lopez-Janove
Arly Marin-Leon
Steve Melendez
Klu Padu
Glenn Pontier
Joyce Salimeno-Gittlin
Brian Scardefield
Gerald J. Skoda
Nicole Slevin
Fred Stabbert, III
Anna Lise Dyhr Vogel
Rabbi Larry Zierler

Dear Bill,

Let me begin by wishing you well from all of us here at Sullivan Renaissance.

Congratulations on being selected to receive a Sullivan Renaissance 2020 Municipal Partnership Grant. Attached to this letter is an addendum with details on your grant package, and a list of conditions and/or recommendations from the grant review committee. Please sign, date, and return one copy to our office; and retain the other copy for your records.

Allison Cappella, Community Development Program Manager, will deliver the grant, a binder to document your project, and other materials during the week of May 4th. If other arrangements are required, please let us know.

As you begin working on your project, please keep the following dates in mind:

Progress reports must be submitted by the first of the month (June, July, August, and September) Due to the COVID-19 pandemic, and the necessary limitations and restrictions that have been imposed for public health and safety, the 2020 Renaissance program has an adjusted timeline. Projects must be completed and project summary, financial documentation, and photos submitted no later than Wednesday, September 30, 2020. The judging process has been suspended for the 2020 season.

We ask that any documentation or publicity in connection with your project include the following language: "Funding for this project was made possible in part by a Municipal Partnership Grant from Sullivan Renaissance."

If you have any questions, or need assistance as you proceed, please do not hesitate to contact Allison at 845.295.2462.

Thank you for continuing to build beautiful, active communities in Sullivan County. We look forward to working with you this season; when we are through this difficult time and are able to come together again.

Until then, be safe and be well.

Sincerely,

Denise Frangipane, Executive Director

*Wishing you
all the best,
Denise*

Encl: 2020 Municipal Partnership Grant Addendum

Spray Paver
Installed
Bonded Wearing
Course (Various)
For Hwy Dept. #5

BIDDER'S QUALIFICATIONS

The undersigned guarantees the accuracy of all statements and answers herein contained. (Please print in ink).

1. How many years has your firm been in business? 103 years.
2. List up to three (3) projects in New York State of this nature that you have completed in the last three (3) years and give the name, address and telephone number of a reference from each. Also, give the original contract bid price and the completed cost of each project listed.

Saratoga County, Keith Manz, 3654 Galway Road, Ballston Spa, NY 12020, 518-885-2235 \$300,000.00

Town of Wallkill, Mike Aumick 99 Tower Drive, Middletown, NY 10940, 845-361-1106 \$200,000.00

Town of Blooming Grove, Wayne Kirkpatrick, 2741 Route 94, Blooming Grove, NY 10914, 845-496-3816 \$200,000.00

3. State the true, exact, correct and complete name of the partnership, corporation or trade name under which you do business and the address of the place of business. (If a corporation, state the name of all partners. If a trade name, state the names of the individuals who do business under the trade name). It is absolutely necessary that this information be furnished.

<u>Gorman Bros., Inc.</u>	<u>Albert M. Gorman</u>
<u>200 Church Street</u>	<u>P. Anthony Gorman</u>
<u>Albany, NY 12202</u>	

GENERAL:

In addition to the foregoing, the Town may make such investigations it deems necessary to determine the ability of the Bidder to perform the work. The bidder shall furnish to the Town, within five (5) days of a request, all such information and data for this purpose as may be requested. The Town reserves the right to reject any bid if the information submitted by, or investigation of, a bidder fails to satisfy the Town that such bidder is properly qualified to carry out the obligations of the contract and to complete the work contemplated therein. Conditional bids will not be accepted.

Spray Paver Installed Bonded Wearing Course Bid Form

<u>Item No.</u>	<u>Material</u>	<u>0-350 Tons/Day</u>	<u>351-700 Tons/Day</u>	<u>701+ Tons/Day</u>
1	PPST Type A	300.00	250.00	240.00
2	PPST Type B	295.00	245.00	235.00
3	PPST Type C	295.00	245.00	235.00
4	9.5mm (Type 7 HMA)	185.00	145.00	130.00
5	12.5mm (Type 6 HMA)	180.00	140.00	125.00
6	6.3mm Polymer Modified	190.00	150.00	135.00

7. Trucking Rate \$ 150.00 /hour
8. Rebate Milling – 18" \$ 20.00 /linear foot
9. Price Per Flagger \$ 1,000.00 /day
10. Price Per Additional Laborer \$ 1,000.00 /day

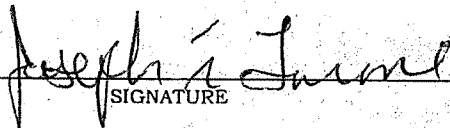
 SIGNATURE	Joseph T. Farone PRINTED
Chief Executive Officer	4/28/20
TITLE	DATE
Gorman Bros., Inc.	518-462-5401
COMPANY NAME	PHONE
200 Church Street, Albany, NY 12202	518-462-1296
ADDRESS	FAX

TO: TOWN BOARD OF THE TOWN OF THOMPSON

The undersigned, having a principal place of business at the address set forth below being experienced and responsible for the performance of same, agrees to furnish and deliver to the Town of Thompson at the locations herein specified, or if no location is specified, or if no location is specified, to the Town Hall, Town of Thompson, Monticello, New York 12701, the following described item, material or service in accordance with the attached specifications and described in detail below.
(attach additional material to Proposal, if necessary).

NON-COLLUSIVE BIDDING CERTIFICATION

By submission of this bid, each bidder and each person signing on behalf of any bidder certifies, and in the case of a joint bid, each party thereto certifies as to its own organization, under the penalty of perjury, that to the best of his knowledge or belief:

(1) The prices of this bid have been arrived at independently without collusion, consultation, communication or agreement, for the purpose of restricting competition, as to any matter relating to such prices with any other bidder or with any competitor.
2) unless otherwise required by law, the prices which have been quoted in this bid have not been knowingly disclosed by the bidder and will not knowingly be disclosed by the bidder prior to opening, directly or indirectly, to any other bidder or to any competitor.

(3) no attempt has been made or will be made by any bidder to induce any other other person, partnership or corporation to submit or not to submit a bid for the purposes of restricting competition

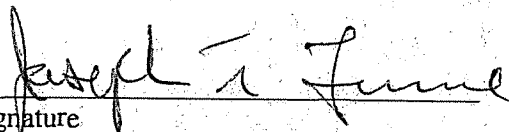
Signature

Joseph T. Farone, Chief Executive Officer
Printed Name and Title

4/28/20
Date



AFFIRMATIVE ACTION PLAN/EEO POLICY STATEMENT

It is the policy and practice of Gorman Bros. Inc/The Gorman Group, LLC to assure that no person will be discriminated against or denied the benefits of any activity, program or employment process receiving public funds, in or in part, in the areas of employment, recruitment, advertising, hiring, upgrading, promoting, transferring, demoting, layoffs, terminations, rehiring, employment and/or rates of pay and other compensations. We will not discriminate in the selection and retention of subcontractors, including procurement of materials and leases of equipment.

This firm is an Affirmative Action/Equal Opportunity Employer and is strongly committed to all policies which will afford equal opportunity employment to all qualified persons without regard to an individual's race, color, religion, age, sex, marital status, national origin, or disability. Such action shall include; employment, upgrading, demotion or transfer; recruitment or recruitment advertising; layoff or termination; rates of pay or other forms of compensation; and selection for training, including apprenticeship, pre-apprenticeship, and/or on the-the-job training.

Gorman Bros. Inc/The Gorman Group, LLC will implement, monitor, enforce and achieve full compliance with this Affirmative Action Policy Statement in conjunction with the applicable federal and state laws, regulations, executive orders and contract provisions, including but not limited to those listed below:

Dissemination of Policy:

The actions taken by Gorman Bros. Inc/The Gorman Group, LLC to implement our EEO policy shall include:

1. Meeting with employees periodically to review, explain, and discuss such policy.
2. Training all new employees the aspects of our EEO obligations.
3. Posting notices and posters setting forth our firm's EEO policy in areas readily accessible to employees both current and potential.
4. Bringing to the attention of our employees such policy by means of meetings, employee handbooks and other appropriate means.

Recruitment:

In implementing this policy and ensuring that equal opportunity is being provided to protected class members, and in addition to the normal procedures for filling a job (i.e., placing ads in major newspapers, employee referrals), each time a hiring opportunity occurs this firm will contact and request referrals from minority and female organizations, and media sources. All advertising will emphasize that the firm is "An Affirmative Action/Equal Opportunity Employer." Gorman Bros. Inc/The Gorman Group, LLC will also contact and obtain job quotations from MBE and WBE Companies as sub contractors whenever and wherever possible.

In order to substantiate this firm's efforts and affirmative actions to provide equal opportunity, the firm will maintain and submit, as requested, documentation such as referral request correspondence, copies of advertisements utilized and follow-up documentation to substantiate that efforts were made in good faith. This firm will maintain internal EEO/affirmative action audit procedures and reporting, as well as record keeping systems. Such information will be retained for a period of three years following completion of the contract work and shall be available at reasonable times in the Gorman Bros. Inc/The Gorman Group, LLC's Albany, NY office for inspection by authorized representatives of the State DOT and/or the USDOT.

Personnel Action:

Wages, working conditions, and employee benefits shall be established and administered without regard to race, color, religion, sex, national origin, age, or disability. The following procedures will be followed:

1. Gorman Bros. Inc/The Gorman Group will conduct periodic inspections of project sites to insure that working conditions and employee facilities do not indicate discriminatory treatment of personnel.
2. Gorman Bros. Inc/The Gorman Group will promptly investigate all complaints of alleged discrimination and take corrective action in any and all situations where there is evidence of discrimination.
3. Gorman Bros. Inc/The Gorman Group will periodically evaluate the spread of wages paid within each classification to determine any evidence of discriminatory wage practices.

Training and Promotion:

Gorman Bros. Inc/The Gorman Group will assist in locating, qualifying, and increasing the skills of minority group and women employees, and applicants for employment. The company will advise employees and applicants for employment of available training programs and periodically review the training and promotion of potential minority groups and woman employees. We will encourage eligible employees to apply for such training and promotion.

Selection of Subcontractors:

Gorman Bros. Inc/The Gorman Group will not discriminate on the grounds of race, color, sex, national origin, age or disability in the selection and retention of subcontractors, including procurement of materials and leases of equipment. We will use our best efforts to ensure subcontractor compliance with Federal and State Equal Opportunity and EEO requirements.

Records and Reports:

Gorman Bros. Inc/The Gorman Group shall keep records as necessary to document compliance with EEO requirements and shall retain such reports for a period of three years following completion of the contract work. They shall be available at reasonable times and places for inspection by authorized representatives of the State DOT and/or USDOT.

It is understood by our firm, including the Equal Employment Opportunity Officer and supervisory and managerial personnel that failure to effectively implement, monitor and enforce this firm's affirmative action program and failure to adequately document the affirmative action steps taken will result in this firm being required to recommit itself to a modified and more stringent affirmative action program prior to receiving approval. It is recognized that an approved affirmative action program is a prerequisite for performing services for the contracting agency. This plan, in addition to the State DOT's EO/EEO contract provisions and requirements, shall constitute our Affirmative Program.

Managers and supervisors are being advised of their responsibilities to ensure the success of the program. The ultimate responsibility for the Affirmative Action Program rests with the Chief Financial Officer/Senior Vice President. However, the day-to-day duties will be coordinated by Sandra Lee McKay, who has been designated the Equal Opportunity Officer of Gorman Bros. Inc/The Gorman Group.

In addition, each manager and supervisor, and all employees are directed to aid in the development and implementation of the program and will be held responsible for compliance to its objectives.

Joseph T. Farone Jr

Joseph T. Farone Jr.
Chief Financial Officer/Senior Vice President



Paver-Placed Surface Treatment



Description

- Seals existing road surface and provides a new skid resistant ultra thin wearing course
- Self-priming paver applies an emulsion bond coat directly in front of paving screed when an ultra thin overlay of hot mix asphalt is placed
- Three types: Type A is a 1/4" maximum aggregate size mix, Type B is a 3/8" maximum aggregate size mix, and Type C is a 1/2" maximum aggregate size mix and the most heavy-duty mix
- Expected service life of 10 years

All Roads Lead To
GORMAN

www.gormanroads.com



Advantages

- No curing time required – opened to traffic immediately after rolling
- Reduces “misting” on wet pavements - macro-texture yields high skid resistance
- Minimal change in pavement elevation
- Low surface noise
- Suitable for all traffic volumes
- Conserves high quality aggregates
- Addresses oxidized and weathered pavement
- Expected service life of 10 years



Which road would you rather drive on in the rain?

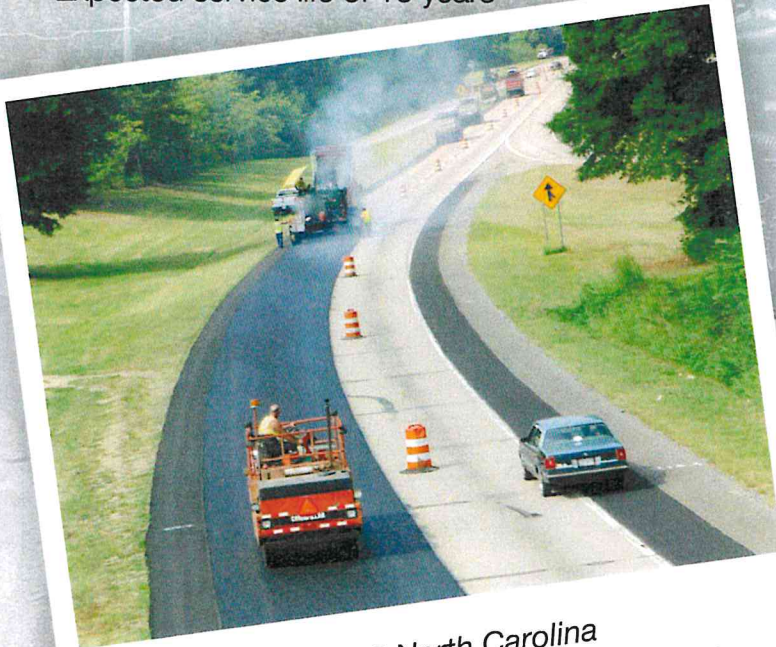

Rt. 1-85 North Carolina

Conditions For Use

- Low severity cracking or raveling
- Infrequent corrugations, settlements, heaves or slippage cracks
- Medium severity rutting

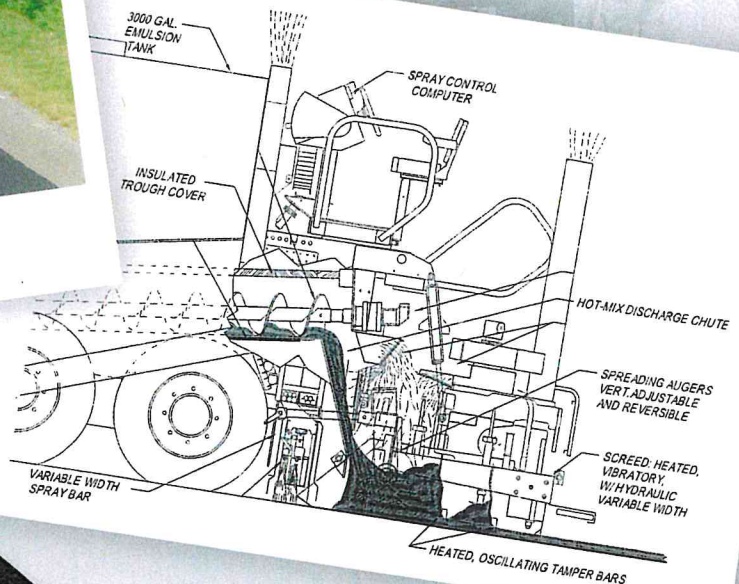

THE GORMAN GROUP

Ask your Gorman sales representative or visit our website for more information on all of our Pavement Preservation Products.

#6

Town of Thompson

Town Hall
4052 State Route 42
Monticello, NY 12701

Water and Sewer Department

Phone: (845) 794-5280

Fax: (845) 794-2777

Email: waterandsewer@townofthompson.com

Michael Messenger, Superintendent
Keith Rieber, Assistant Superintendent

BILLS OVER \$2500.00

We are requesting permission to pay the attached invoice.

VENDOR: Hydra-Numatic Sales Co.

DESCRIPTION: Impellers for Pump Station

AMOUNT: \$ 4,047.08

Sole Source

Invoice

TEL: 973-492-0181
 FAX: 973-492-1909

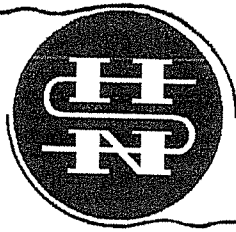

HYDRA-NUMATIC SALES CO.

22 PARK PLACE • P.O. BOX 760 • BUTLER, NJ 07405

www.hnscompany.com

Email: Sales@hnscompany.com

Invoice Number: 55208	Invoice Date: Apr 14, 2020	Page: 1
--------------------------	-------------------------------	------------

Sold To: Town Of Thompson
 4052 Rt. 42, Town Hall
 Monticello, NY 12701

Ship To: Town of Thompson Sewer & Water
 Kiamesha Lake WWTP
 128 Rock Ridge Drive
 Monticello, NY 12701

Customer ID THOMPSON NY	Customer PO 96436	Payment Terms Net 30 Days
Shipping Method UPS Ground	Ship Date Apr 14, 2020	Due Date May 14, 2020
		Sales Order Number 17319

Quantity	Description	Unit Price	Extension
	Attn: Keith Rieber For SN 07-6398-E, Thompson NY		
1.00	ZS60B252A CW X-PELLER	1,883.90	1,883.90
1.00	ZS60B252B CCW X-Peller	1,883.90	1,883.90
2.00	ZS60A12 B and C shaft impeller bolt	16.15	32.30
2.00	ZS60A20 B and C shaft impeller washer	12.80	25.60
2.00	ZS60A26 Volute gasket 1/32"	18.81	37.62

Tax Exempt Cert on file?

Subtotal	3,863.32
Sales Tax	0.00
Shipping & Handling	183.76
Total Invoice Amount	4,047.08
Payment/Credit Applied	0.00
TOTAL	4,047.08

1-1/2% per month service charge will be applied to all past due accounts. A convenience fee may be for payments by credit card.

TEL: 973-492-0181
 FAX: 973-492-1909

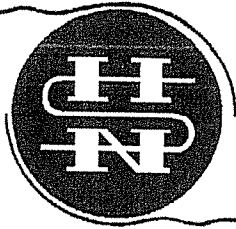

HYDRA-NUMATIC SALES CO.

22 PARK PLACE • P.O. BOX 760 • BUTLER, NJ 07405

www.hnscompany.com

Email: Sales@hnscompany.com

Order Acknowledgement

Sales Order Number
17319

Sold To: Town of Thompson
 4052 RT. 42, Town Hall
 Monticello, NY 12701

Ship To: Town of Thompson Sewer & Water
 Kiamesha Lake WWTP
 128 Rock Ridge Drive
 Monticello, NY 12701

Sales Order Date
Feb 10, 2020

TEL: 1-845-794-5280

FAX: 1-845-794-2777

Page:
1

Customer ID THOMPSON NY	PO Number 96436	Address questions to: Erin ext 105
Payment Terms Net 30 Days	Shipping Method Best Way	Email: erinf@hnscompany.com

Tax Exempt Cert on file?

Quantity	Item	Description	Unit Price	Extension
		Attn: Keith Rieber For SN 07-6398-E, Thompson NY		
1.00	ZS60B252A	ZS60B252A CW X-PELLER	1,883.90	1,883.90
1.00	ZS60B252B	ZS60B252B CCW X-Peller	1,883.90	1,883.90
2.00	ZS60A12	ZS60A12 B and C shaft impeller bolt	16.15	32.30
2.00	ZS60A20	ZS60A20 B and C shaft impeller washer	12.80	25.60
2.00	ZS60A26	ZS60A26 Volute gasket 1/32"	18.81	37.62
		Pricing does not include shipping and handling charges		

ALL shipments are FOB Factory. Taxes will be added when applicable. All parts orders receive a handling charge of 5%; minimum charge \$15.00. A convenience fee may be added for payment by credit card.

Return Policy: Merchandise determined by Hydra-Numatic to be in good resalable condition be returned for credit or refund if a valid RMA number is obtained from us. Returns that are related to warranty issues will be subject to a minimum 15% restocking charge, unless a part exchange of equal or greater value is made. Exchanges do not qualify for free shipping or

Subtotal 3,863.32

Sales Tax

Shipping & Handling To be determined

TOTAL ORDER AMOUNT 3,863.32

Visit our new and improved online store at DIYControls.com!

Hydra-Numatic Sales Company terms prevail over any terms detailed on purchase orders or other correspondence sent to Hydra-Numatic Sales, unless expressly stated otherwise.

Quotation



HYDRA-NUMATIC SALES CO.

TEL: 973-492-0181
FAX: 973-492-1909

22 PARK PLACE • P.O. BOX 760 • BUTLER, NJ 07405

www.hnscompany.com

Email: Sales@hnscompany.com

Quoted to:

Town of Thompson
4052 RT. 42, Town Hall
Monticello, NY 12701

Ship to:

Kiamesha Lake WWTP
128 Rock Ridge Drive
Monticello, NY 12701

Quote Number

20-00017

Quote Date

Feb 7, 2020

TEL: 1-845-794-5280

FAX: 1-845-794-2777

Please contact us if you have any questions.

Page:

1

Customer ID	Pricing Valid Until	Sales Rep	Sales Rep Email
THOMPSON NY	3/8/20	Erin x105	erinf@hnscompany.com

Pricing does not include shipping and handling* or taxes if they apply. Please contact our office to place an order.

Quantity	Item	Description	Unit Price	Extension
		Attn: Keith Rieber For SN 07-6398-E, Thompson NY		
1.00	ZS60B252A	ZS60B252A CW X-PELLER	1,883.90	1,883.90
1.00	ZS60B252B	ZS60B252B CCW X-Peller	1,883.90	1,883.90
2.00	ZS60A12	ZS60A12 B and C shaft impeller bolt	16.15	32.30
2.00	ZS60A20	ZS60A20 B and C shaft impeller washer	12.80	25.60
2.00	ZS60A26	ZS60A26 Volute gasket 1/32"	18.81	37.62
		Pricing does not include shipping and handling charges		

#6

ALL shipments are FOB Factory. Taxes will be added when applicable. Shipping is additional unless exclusively noted. HNS Terms and Conditions govern all orders. All parts orders receive a handling charge of 5%; minimum charge \$15.00. A convenience fee may be added for payments by credit card.

Subtotal	3,863.32
Sales Tax	
Total	3,863.32

Return Policy: Merchandise determined by Hydra-Numatic to be in good resalable condition can be for credit or refund if a valid RMA number is obtained from us. Returns that are not related to warran will be subject to a minimum 15% restocking charge, unless a product exchange of equal or greater made. Exchanges do not qualify for free shipping offers.

Visit our new and improved online store at DIYControls.com!

#6

Town of Thompson

Town Hall
4052 State Route 42
Monticello, NY 12701

Water and Sewer Department

Phone: (845) 794-5280

Fax: (845) 794-2777

Email: waterandsewer@townofthompson.com

Michael Messenger, Superintendent
Keith Rieber, Assistant Superintendent

BILLS OVER \$2500.00

We are requesting permission to pay the attached invoice.

VENDOR: Bluetarp Credit Services (Northern Tool & Equipment)

DESCRIPTION: Pallet Jack

AMOUNT: \$ 4883.74

Quotes attached

* Verbal Approval Attached *

was the contractor on the Patio Homes Pump Station Sewage Force Main Replacement Project came back repaired the lateral. However the (POA) has these other outstanding bills and has requested that the Town pay for them since the lateral damage was occurred during the project. Comptroller Melissa DeMarmels said that if the Town Board agrees to pay the expenses then the bills must be made out to the Town of Thompson. The Town would pay the expenses directly to the vendor and not to the (POA). Further discussion was held and the Town Board agreed to pay the outstanding expenses if they are made out to the Town.

The Following Resolution Was Duly Adopted: Res. No. 150 of the Year 2020.

Resolved, that the Town Board of the Town of Thompson hereby authorizes payment of the outstanding expenses of A Plus Sewer Service for \$675.78 and of Joseph Pressano for \$150.00 for a total amount of \$825.78 for plumbing services of a damaged lateral to the Patio Homes (POA) Clubhouse that occurred as a result of the Patio Homes Pump Station Sewage Force Main Replacement Project.

Motion by: Councilman Schock

Seconded by: Councilman Mace

Vote: Ayes 5 Rieber, Pavese, Schock, Meddaugh and Mace

Nays 0

SUPERVISOR'S REPORT:

Supervisor William J. Rieber, Jr.

- Karen Schaefer, the Supervisor's Confidential Secretary lost her father yesterday evening at the age of 99 years.

COUNCILMEN & DEPARTMENT HEAD REPORTS:

Water & Sewer Superintendent Michael G. Messenger

- Meeting with representatives of MH&E Consulting Engineers DPC regarding the Engineering Agreements for the Harris Sewer Pump Station and the Emerald Green Sewer Pump Station 1, 2 & 3 Projects – Project options, funding and financing options and try to obtained cooperation with the Village of Monticello. Discussion was held regarding the subject.
- Request to replace Pallet Jack Lift up to 4,000 lb. capacity, he said the current jack they have is not safe for the necessary use. – He obtained (2) price quotes from Northern Tool & Equipment for \$4,529.99 + Shipping and from Home Depot for \$4,599.28 + Shipping. The Town Board gave Supt. Messenger a verbal okay to purchase. He will order the Pallet Jack Lift and submit the bill to the Town Board once it has been received.

Councilman Ryan T. Schock

- MFD Pancake Breakfast on 03/15/2020, 7am-12pm.

Councilwoman Melinda S. Meddaugh

- Town of Thompson Social Media Blog, Facebook Page – Photo's to be taken of the Town Board to display. Questionnaire was also provided to the Town Board for completion and return.

PO#100042

QUOTE #1



NorthernTool.com | 1-800-221-0516 | Available Online Only

Vestil Pallet Master Pallet Server — 12V DC Power, 4,000-Lb. Capacity, Model# PMP5-60-DC

Item# 855867

New — [Write a Review](#)

23-25 DAYS

Only \$4529.99

Easy Financing Available | [Learn More](#)



APPROVED

3/3/2020

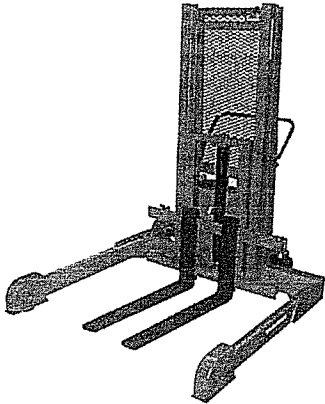

Ship It

Factory Shipped —

Estimated Delivery: 23 - 25 Business Days

- Unique straddle design works well with pallets and skids with and without an understructure
- Ideal for loading and unloading semi-trailers
- 12V DC power standard with on-board charger
- Push buttons to raise and lower lift are located on power unit
- Hand control on coil cord

Product Summary

This Vestil pallet master/server enables one person to easily move fully loaded pallets, skids and crates (with or without an understructure) without the use of a fork truck. U.S.A.

What's Included

(1) Pallet master/server

Penny - 3/5/20

\$353.75 SHIPPING

\$4883.74 TOTAL

Features + Benefits

- Unique straddle design works well with pallets and skids with and without an understructure
- Ideal for loading and unloading semi-trailers
- 12V DC power standard with on-board charger
- Push buttons to raise and lower lift are located on power unit
- Hand control on coil cord

LACC. HELP DESK @ NORTHERNTOOL.COM

ASK # 63082586

Key Specs

Item#	855867	Overall Dimensions L x W (in.)	67 3/16 x 58 x 82 3/8
Brand	<u>Vestil</u>	Wheel Type	Phenolic
Manufacturer's Warranty	12 months limited parts / No labor	Wheel Size (in.)	8 x 2
Ship Weight	1042.0 lbs	Wheels (qty.)	2
Load Capacity (lbs.)	4,000	Caster Type	Swivel
Lowered Height (in.)	3	Caster Size (in.)	8 x 2
Raised Height (in.)	60	Winch Included	No
Extension Width (in.)	4	Material Type	Steel
Fork Thickness (in.)	1 1/2	Turning Radius (in.)	180
Extension Length (in.)	36	Includes	Built-in, key-operated ON/OFF control for security/floor lock
Width Between Forks (in.)	Adjustable 8 in.-32 in.		

Compare with Most Popular Pallet Stackers

Currently Viewing

Item# 855864

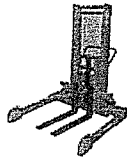

Vestil Pallet Master Pallet Server — DC Power, 4,000-Lb. Capacity, Model# PMPS-50-DC (Not Yet Rated)

Only \$4779.99

Item# 855867

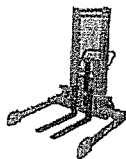

Vestil Pallet Master Pallet Server — 12V DC Power, 4,000-Lb. Capacity, Model# PMPS-60-DC (Not Yet Rated)

Only \$4529.99

Item# 52449



Strongway Manual Pallet Stacker — 2200-Lb. Capacity, 98in. Max. Lift

★★★★★ (3)
Reg. \$1,569.99
Sale \$1449.99
Save \$120.00

Item# 856040

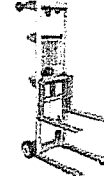

Vestil Hand Winch Truck — 500-Lb. Capacity, Model# A-LIFT-R

(Not Yet Rated)

Only \$749.99

Item# 144313



Genie 8 Ft. Ladder Option for Genie GL-8 Lift (Ladder Only) — Model# 37249-S

(Not Yet Rated)

Only \$419.99

Load Capacity (lbs.)	4,000	4,000	2,200	500	-
Lowered Height (in.)	3	3	-	3.5 (forks down), 23.5 (forks up)	-
Raised Height (in.)	50	60	98.43	47 (forks down) 67 (forks up)	8
Extension Width (in.)	4	4	57.09	4	-
Fork Thickness (in.)	1 1/2	1 1/2	1 3/16	1 3/4	-
Extension Length (in.)	36	36	61.42	22	-
Width Between Forks (in.)	Adjustable	Adjustable 8 in.–32 in.	0–29.53	12 3/4	-
Outside Fork Width (in.)	-	-	7.87–37.40	21	-
Overall Dimensions L x W (in.)	-	67 3/16 x 58 x 82 3/8	61 27/64 x 57 3/32	35 x 25	-
Wheel Type	-	Phenolic	Nylon fork	Nonmarking	-
Wheel Size (in.)	8 x 2	8 x 2	3.27 x 2.36	8	-
Wheels (qty.)	2	2	4 (front)	2	-
Caster Type	Swivel	Swivel	Universal wheel	Swivel	-
Caster Size (in.)	8 x 2	8 x 2	5.79 x 1.57	2	-
Winch Included	-	No	-	Yes	No
Material Type	Steel	Steel	Steel	Steel, aluminum	Aluminum
Turning Radius (in.)	-	180	47 1/4	180	-
Includes	Built-in, key-operated ON/OFF control for security/floor lock	Built-in, key-operated ON/OFF control for security/floor lock	Foot pedal	Winch w/reversible handle and a hold-down device for securing the carriage during transport	-

Similar Options to Consider



Bon Tool 100 lbs.
Load Capacity
Swivel Head Hoist
(1)

\$176⁰⁰



Vestil 1,000 lb.
Capacity Floor
Mounted Jib
NOT YET RATED

\$1483⁷⁰



Vestil 2,000 lb. 4
ft. to 7 ft.
Galvanized DC
NOT YET RATED

\$3177³⁰



Shoulder Dolly
Accessory Hooks
(2-Pack)
(1)

\$19⁰³



Vestil >
Width
Materi:
NOT YET

\$16⁰⁰

Internet #303207738

Model # PMPS-60-DC

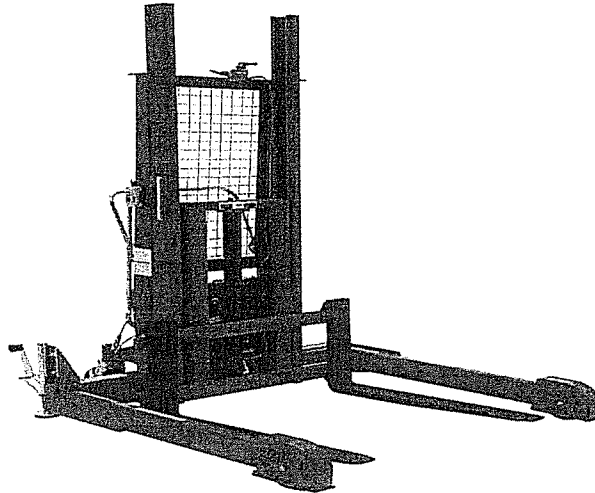

Save to Favorites

Vestil

60 in. DC Powered Pallet Master

Write the first Review

\$4,599²⁸

OR

\$767⁰⁰ per month* suggested payments with
6 months* financing on this \$4599.28 purchase*.

Apply for a Home Depot Consumer Card

LET'S PROTECT THIS.

Add a 3-year Home Depot Protection Plan for **\$349.00**
[Learn More](#)

Quantity

Hurry, only a few left!

Pick Up In Store

This product can't be picked up in stores

or

We'll Deliver It to You

Standard Delivery

Expect it **March 27 - April 3**

[Add to Cart](#)

Delivery Options

Your Fastest Checkout

Turn on Instant Checkout

We're unable to ship this item to homes and stores in:

AK, GU, HI, PR, VI

Product Overview

Model #: PMPS-60-DC

Internet #: 303207738

The Pallet Master/Server enables 1 person to easily move fully loaded pallets without the use of a fork truck. The unique straddle design works well with pallets and skids with and without an understructure. The unit is ideal for loading and unloading semi-trailers. Hand pendant control on an eight 8 ft. coil cord standard. All welded steel construction.

- Uniform capacity (lbs.): 4,000
- Fork dimensions (length/width): 36 in. x 4 in.
- Lowered/raised height: 3 in. - 50 in.
- Coil cord length: 96 in.
- California residents see Prop 65 WARNINGS

Specifications

Recently Viewed Items

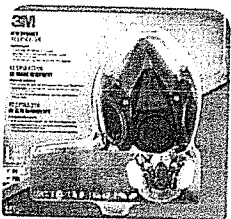

3M Large Paint Project Respirator Mask

(158)

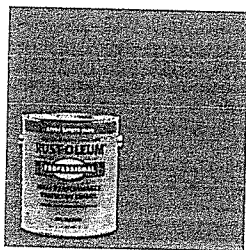

Rust-Oleum Professional 1 gal. High

(87)

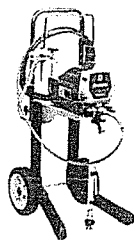

Graco Magnum X7 Airless Paint Sprayer

(1006)

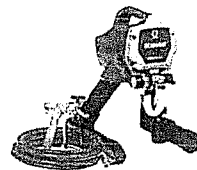

Graco Magnum X5 Airless Paint Sprayer

(1386)



BORDO 8 mm to 22 mm, 5/16 in.-7/8 in. Chamfer

NOT YET RATED

Keith Rieber

From: Northern Tool + Equipment <CustomerCare@northerntool.com>
Sent: Friday, March 6, 2020 12:00 PM
To: krieber@townofthompson.com
Subject: Your Northern Tool Order Has Been Received



NORTHERNTOOL.COM | [CONTACT US](#)

Order Received

Thank you for your recent order. Your order details can be found below.

You will receive an email confirmation that includes tracking information when your order ships.

Order Number:
63082586

Your order summary:

Item#	Description	Price	Quantity	Total
 <u>855867</u>	PALLET MASTER / SERVER	\$4,529.99	1	\$4,529.99
		Subtotal		\$4,529.99
		Shipping		\$353.75
		Tax		\$.00
		Total		\$4,883.74

Note: Order total may not reflect special offers or promotions. Adjustments will be reflected on the final invoice.

Billing Address:

TOWN OF THOMPSON
33 JEFFERSON ST
MONTICELLO, NY 12701-1126

Shipping Address:

TOWN OF THOMPSON
PARKS DEPT
128 ROCK RIDGE DR
KIAMESHA LAKE, NY 12751

Email: CustomerCare@NorthernTool.com

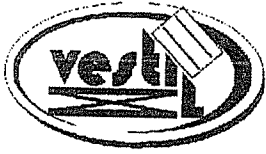

VESTIL MANUFACTURING CORP.
 2999 N. WAYNE ST.
 P.O. BOX 507
 ANGOLA, IN 46703-0507
 PHONE: 260-665-7586
 FAX: 260-665-1339
 www.vestil.com
 FEDERAL ID NO. 35-1709022

Order Number:

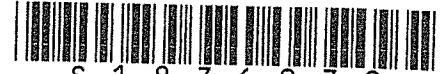

S 1 8 7 6 9 7 9
 Shipment Number: SS2207561

PACKING SLIP

Bill To: NORTHERN TOOL & EQUIPMENT
 -
 P.O. BOX 1937
 BURNSVILLE, MN 55337-0910

Ship To: TOWN OF THOMPSON
 KEITH RIEBER PO Notes:
 128 ROCK RIDGE DR
 PARKS DEPT.
 KIAMESHA LAKE, NY 12751
 UNITED STATES

Phone: 952-894-9510
 Fax: 952-894-4714
 I.D. Number: NRHTLEQPT
 P.O. Number: 4482590
 CA#: 03/09/20
 Dept. Number: 001

Ship MkRefAttn: KEITH RIEBER
 Order Date: 03/06/20
 Shipment Date: 04/14/20
 Ship Method: THIRD PARTY PAY
 Ship Agent/ Delivery Typ: FEDEXFLTP Grnd

Ordered	Shipped	Back Ordered	Item Number	Item ID No.	Unit	V No.	Bin Loc	Description
1	1		855867		EACH	PMPS-60-DC	***	DC PALLET MASTER/SERVER 60 IN 4000 LB

Packing Scheme and Weight(s): 1@1093 6' 64x64x92

Handwritten signature
 4/16/20

PAMG



Northern Tool & Equipment
 BlueTarp Credit Services
 PO BOX 105525
 ATLANTA, GA 30348-5525

651411 111 03 000103 01 NNNNNN
 Michael Messenger
 Town of Thompson Sewer & Water Dept
 4052 State Route 42
 Monticello, NY 12701-3279

Credit Account #
 101170
Northern Tool & Equipment Account #
 10224896
Invoice #
 44655961



Purchase Details		Purchase Location	
Invoice Date	04/14/2020	Name	Northern Tool - Mail Order
Job Code	100092	Address	2800 Southcross Dr W Burnsville, MN 55306
PO #	100092	Phone	(952) 894-9510
Type	Sale	Ship To	
Authorization #	162449679	Name	TOWN OF THOMPSON
Terms	Standard	Address	128 ROCK RIDGE DR KIAMESHA LAKE, NY 12751
Due Date	05/14/2020		
Amount Due	\$4,883.74		

SKU	Description	\$/Unit	Units	Total
855867	855867 PALLET MASTER / SERVE Delivery	\$4,529.99	1.00	\$4,529.99
		\$353.75	1.00	\$353.75
			Sub Total:	\$4,883.74
			Sales Tax:	\$0.00
			Invoice Total:	\$4,883.74

Pay Online at <https://northerntool.bluetarp.com>
 Contact BlueTarp at (888) 321-6698 or help@bluetarp.com with questions.

Town of Thompson Sewer & Water Dept
 4052 State Route 42
 Monticello, NY 12701-3279

Credit Account # 101170
Invoice # 44655961
Authorization # 162449679
Due Date 05/14/2020
Amount Due \$4,883.74

Please indicate address changes below:

Amount Enclosed: _____

BlueTarp Credit Services
 PO BOX 105525
 ATLANTA, GA 30348-5525

01624496790000000000000673712000000000000124410200004883742